

# AGITATORS

Equipment Selection Guide

**FLUID HANDLING**

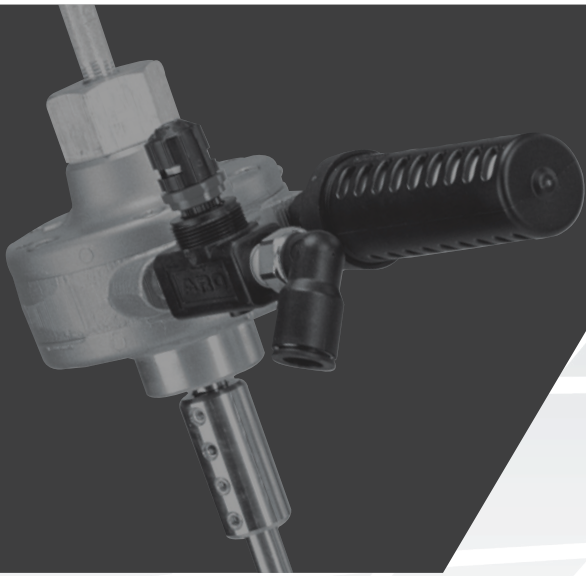

Maximize Production.  
Optimize Results.

# AGITATORS

## Equipment Selection Guide

**Binks has developed a complete upgrade to the agitators used in conjunction with existing pressure tanks (both light and heavy-duty applications).**

The new worm gear agitator drive units offer:

- Superior oil drainage
- No need for safety guards (no exposed drive parts)
- 20:1 reduction (versus 15:1) that requires less air consumption for the same output shaft speed
- 20:1 reduction box (new style)
- Backward compatibility for easy upgrades on current and past pressure tanks.

The new agitators will be applicable to 2, 5, 10, 15, 30 and 60 gallon pressure tanks, 5 and 10 gallon pails, and open or closed drums up to 55 gallons that use agitators to mix fluid materials.

### QUICK REFERENCE INDEX

Assemblies.....	4-11
Air Motors & Gear Drives.....	12-13
Quick Mixers.....	14-15
Bung Agitators.....	16-17
Agitator Assemblies, Agitators, Drives, Covers & Accessories.....	18-31
Reference Guide .....	32-35
Accessories.....	36-37
Obsolete Items.....	37

*Look for these **Container Icons** throughout this catalog to assist in finding the perfect agitation solution for the containers you use.*



#### LARGE TANKS (30 & 60 GALLONS)

MODEL	DESCRIPTION	SECTION	PAGE
31-396-1	Agitator Gear Drive Unit	Air Motors & Gear Drives	12,34
83-2476	Heavy Duty Agitator Drive	Air Motor Drives	26,32



#### OPEN DRUMS (55 GALLONS)

MODEL	DESCRIPTION	SECTION	PAGE
31-120	Agitator Assembly (C-Clamp)	Agitator Assemblies	18,32,33
31-124	Drum Cover for 55 Gallon Drums	Air Motor Drives	28
31-129	Direct Drive Agitator (with cover)	Assemblies	6,34
31-393-1	Gear Drive Agitator (drive only)	Assemblies	4,32,33
31-397	Gear Drive Agitator (with cover) (replaced 31-131)	Assemblies	10,32,33
31-400	Gear Drive Agitator Complete Assembly (less cover)	Assemblies	8,32,33
31-401-1	Gear Drive Agitator (drive only)	Assemblies	8,32,33
41-3300	Direct Drive Agitator (less cover)	Accessories	6,32,33
41-3304	Direct Drive Agitator (less cover)	Accessories	6,32,33
41-3305	(agitator only)	Accessories	8,32,33
41-9000	Elevator	Agitators & Accessories	29
149-693*	Quick Mixer only, less motor & handle (for 55 gal containers)	Quick Mixers	14,36,37
149-874*	Quick Mixer Complete (for 55 gallon containers)	Quick Mixers	14,34,35
202-55-2	2-Paddle Gear Drive Agitator (with cover)	Assemblies	10,32,33
202-55-4	4-Paddle Gear Drive Agitator (with cover)	Assemblies	10,32,33
843001	Agitator (55 gallon) (agitator assembly only)	Agitators, Covers & Accessories	20,34,35
874506	Drum Cover (55 gallon) (stainless steel drum cover only)	Agitators, Covers & Accessories	20,28

\*Hand Held

# AGITATORS

## Equipment Selection Guide



### CLOSED DRUMS (55 GALLONS)

MODEL	DESCRIPTION	SECTION	PAGE
31-296	Heavy Duty Bung Agitator	Bung Agitators	16,32,33



### CLOSED DRUMS (55 GALLONS—WITH BUILT-IN AGITATORS)

MODEL	DESCRIPTION	SECTION	PAGE
31-393-1	Gear Drive Agitator (drive only)	Assemblies	4,32,33
31-394	Gear Drive Agitator (complete with support assembly)	Accessories	4,32,33
QS-5003-1	Paint Drum Agitator and Gear Drive	Agitators & Accessories	28,29,32,33



### PRESSURE TANKS (2, 5, 10 AND 15 GALLONS)

MODEL	DESCRIPTION	SECTION	PAGE
PT-418	Air Motor & Adapter for 83C	Agitators	22,36
PT-419	SS Shaft Assembly for 83Z	Agitators	22
PT-427	Air Motor & Adapter for 83Z	Agitators	22
PT-428	Shaft Assembly for 83C	Agitators	22
QM-142	Hand Crank	Accessories	36,37
QMG-416	Direct Drive Agitator for use with 183G series (galvanized)	Agitators	22,34,35
QMG-417	Direct Drive Agitator for use with 183G series (galvanized)	Agitators	22,23,34
QMG-418	Direct Drive Agitator for use with 183G series (galvanized)	Agitators	22,23,34
QMG-419	Direct Drive Agitator for use with 183G series (galvanized)	Agitators	22,23,34
QMG-420	Direct Drive Agitator for use with 183G series (galvanized)	Agitators	22,23,34
QMS-430	Direct Drive Agitator for use with 183S series (stainless steel)	Agitators	22,23,34
QMS-431	Direct Drive Agitator for use with 183S series (stainless steel)	Agitators	22,34,35
QMS-432	Direct Drive Agitator for use with 183S series (stainless steel)	Agitators	22,23,34
QMS-433	Direct Drive Agitator for use with 183S series (stainless steel)	Agitators	22,23,34
QMS-434	Direct Drive Agitator for use with 183S series (stainless steel)	Agitators	22,23,34
QS-5012-1	Gear Reduced Air Motor Drive	Agitators & Drives	24,34,35



### PAILS (5 GALLONS)

MODEL	DESCRIPTION	SECTION	PAGE
31-425	Agitator, Drive & Cover assembly	Agitators & Covers	30,34,35
41-3306	Agitator & Drive assembly	Agitators & Covers	30,32,33
41-3312	Agitator & Drive assembly	Agitators & Covers	30,32,33
41-3312-S	Agitator & Drive assembly	Agitators & Covers	30,32,33
41-718810	Pail Cover	Agitators & Covers	30
149-365	Quick Mixer only, less motor and handle (for 5 and 10 gallon containers)	Quick Mixers	14,34-37
149-873	Quick Mixer Complete (for 5 and 10 gallon containers)	Quick Mixers	14,34,35
843000	Agitator (5 gallon) (agitator assembly only)	Agitators, Covers & Accessories	20,34,35
874502	Pail Cover (5 gallon) (stainless steel pail cover only)	Agitators, Covers & Accessories	20



### PAILS (10 GALLONS)

MODEL	DESCRIPTION	SECTION	PAGE
149-365*	Quick Mixer only, less motor & handle (for 5 and 10 gallon containers)	Quick Mixers	14
149-873*	Quick Mixer Complete (for 5 and 10 gallon containers)	Quick Mixers	14

### REFERENCE GUIDE 32-35

### ACCESSORIES / OBSOLETE ITEMS 36-37

\*Hand Held

See Reference Guide (pages 32-35) and Accessories (pages 36-37) for more information

# BINKS GEAR DRIVE AGITATOR

## for 55 Gallon Drums

### Model 31-393-1

Gear Drive Agitator  
(drive only)

### Model 31-394

Gear Drive Agitator  
(complete with support  
assembly)

- For 55 gallon drums with built-in agitator

**Recommended lubricant:** None required.

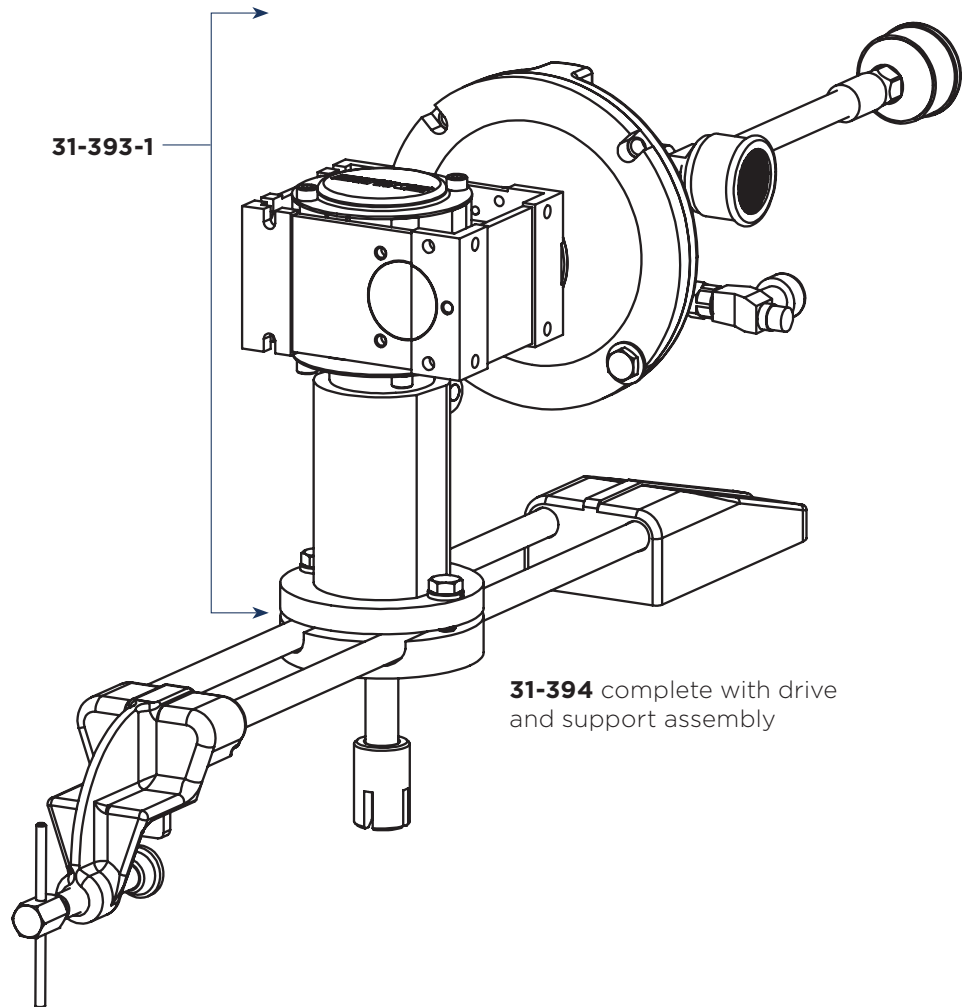

## BINKS GEAR DRIVE AGITATOR

for 55 Gallon Drums

### SPECIFICATIONS

MODEL NUMBER	31-393-1	31-394
Container Size	55 Gal	55 Gal
Shipping Weight (lbs)	18	28
Ref. Part Sheet	77-2991	77-2991

### MOTOR SPECIFICATIONS

Air Motor Model	31-418-1	31-418-1
Gear Box Model (31-416-1)	31-393-1	31-393-1
Drive Type	Gear Reduced	Gear Reduced
HP: (Max)	1 HP	1 HP
CFM: (Max)	30	30
Air Motor Repair Kit	KK-5001-1A	KK-5001-1A
Gear Box Repair Kit	N/A	N/A

### SHAFT SPECIFICATIONS

Mount	Rim	Rim
Diameter	N/A	N/A
Speed: (Max)	40 RPM	40 RPM
Material	N/A	N/A



See Reference Guide (pages 32-35) and Accessories (pages 36-37) for more information

# BINKS DIRECT DRIVE AGITATORS

## for Light Body Materials in Open-top 55 Gallon Drums

### Model 31-129

Direct Drive Agitator  
(with cover)

### Model 41-3300

Direct Drive Agitator  
(less cover)

### Model 41-3304

Direct Drive Agitator  
(less cover)

- For light body materials such as stains and lacquers

**Ref. Part Sheet:** 77-1390

**Speed:** 3000 RPM maximum

**Recommended lubricant:** SAE 10W non-detergent oil, 10-20 drops daily.

**Air supply:** Air supply to the motor should be a minimum of 60 psi gauge pressure.

An air filter/moisture trap is recommended. See *Accessories* section.

**Shipping weight:** 33 lbs.



## BINKS DIRECT DRIVE AGITATORS

for Light Body Materials in Open-top 55 Gallon Drums

### SPECIFICATIONS

MODEL NUMBER	41-3300	41-3304	31-129
Container Size	55 Gal	55 Gal	55 Gal
Shipping Weight (lbs)	12	13	32
Ref. Part Sheet	77-1390	77-1390	77-1390

### MOTOR SPECIFICATIONS

Air Motor Model	83-1922	83-1922	83-1922
Gear Box Model	N/A	N/A	N/A
Drive Type	Direct	Direct	Direct
HP: (Max)	1 HP	1 HP	1 HP
CFM: (Max)	30 CFM@350 RPM	30 CFM@350 RPM	30 CFM@350 RPM
Air Motor Repair Kit	6-183	6-183	6-183
Gear Box Repair Kit	N/A	N/A	N/A

### SHAFT SPECIFICATIONS

Mount	Flange	Flange	Flange
Diameter	1/2" (12.7 MM)	1/2" (12.7 MM)	1/2" (12.7 MM)
Speed: (Max)	3000 RPM	3000 RPM	3000 RPM
Material	Stainless Steel	Stainless Steel	Stainless Steel

### PROPELLER SPECIFICATIONS

Number of Props	2	2	2
Diameter	4 1/2" (114.3 MM)	4 1/2" (114.3 MM)	4 1/2" (114.3 MM)
Material	Aluminum	Stainless Steel	Stainless Steel

### COVER SPECIFICATIONS

Part Number	N/A	N/A	31-124
Size	N/A	N/A	55 Gal
Material	N/A	N/A	Zinc Plated and Clear Chromate

*Air motors and gearboxes are lubricated devices. Air motors require daily lubrication either manually or with an automatic lubricator. Failure to lubricate will accelerate wear and void the warranty. Permanent damage will occur to vanes and rotors, and possibly to other components. See recommended manual or automatic lubricators in the Accessories section. Lubricant type: SAE 10W non-detergent oil. Binks Part No. 207-11155-1 (2 oz. bottle) or 207-11155-2 (16 oz. bottle). Safety Data Sheet: SDS-27.*



See Reference Guide (pages 32-35) and Accessories (pages 36-37) for more information

# BINKS GEAR DRIVE AGITATOR

## for Open-top 55 Gallon Drums

**Model 31-400**  
Gear Drive Agitator  
Complete Assembly  
(less cover)

**Model 31-401-1**  
Gear Drive Agitator  
(drive only)

**Model 41-3305**  
(agitator only)

- For heavy bodied materials such as enamels, epoxies, waterborne materials, etc.
- 20:1 Gearbox/gear-reducer drive

**Speed:** Speed of the air motor is regulated by an air adjusting valve (part no. HAV-500). The speed of the agitator shaft below the gearbox is 30 to 40 RPM and should not run faster than 40 RPM maximum.

**Recommended lubricant:** None required.

**Ref. Part Sheets:** 77-2804 and 77-2991

An air filter/moisture trap is recommended. See *Accessories* section.

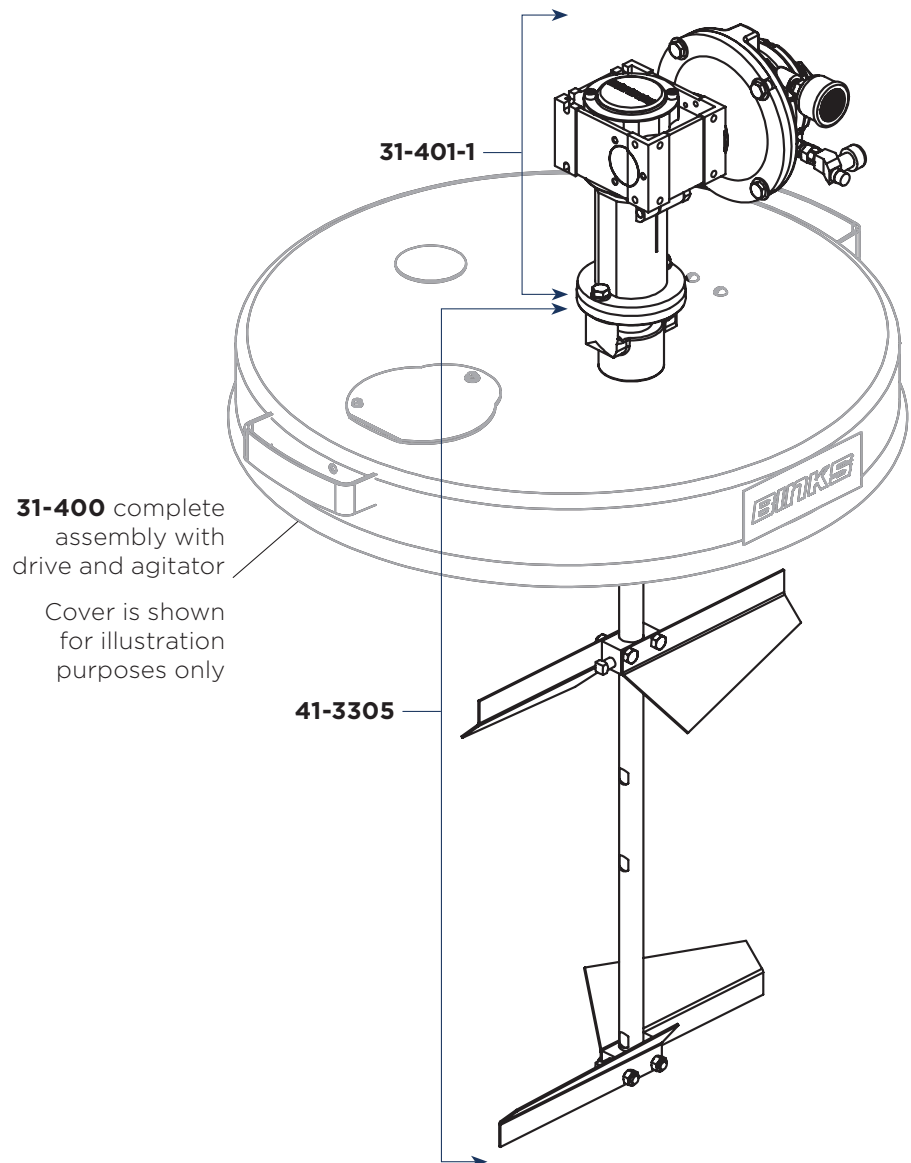



## BINKS GEAR DRIVE AGITATOR

for Open-top 55 Gallon Drums

### SPECIFICATIONS

MODEL NUMBER	31-400	31-401-1	41-3305
Container Size	Open 55 Gal Drum	Open 55 Gal Drum	Open 55 Gal Drum
Shipping Weight (lbs)	31	20	10
Ref. Part Sheet	77-2804	77-2991	77-2991

### MOTOR SPECIFICATIONS

Air Motor Model	31-418-1	31-418-1	N/A
Gear Box Model	31-416-1	31-416-1	N/A
Drive Type	Gear Drive	Gear Drive	N/A
HP: (Max)	1	1	1
CFM: (Max)	30	30	30
Air Motor Repair Kit	KK-5001-1A	KK-5001-1A	KK-5001-1
Gear Box Repair Kit	N/A	N/A	N/A

### SHAFT SPECIFICATIONS

Mount	Flange	Flange	Flange
Diameter	7/8" OD	7/8" OD	7/8" OD
Speed (Avg)	30-40 RPM	30-40 RPM	30-40 RPM
Material (Type 304)	Stainless Steel	Stainless Steel	Stainless Steel

### PROPELLER SPECIFICATIONS

Number of Props	2	2	2
Diameter	14.5"	14.5"	14.5"
Material (Type 304)	Stainless Steel	Stainless Steel	Stainless Steel

### COVER SPECIFICATIONS

Part Number	31-124	31-426	N/A
Size	55 Gal	55 Gal	N/A
Material	Plated Steel	Stainless Steel	N/A



See Reference Guide (pages 32-35) and Accessories (pages 36-37) for more information

# BINKS GEAR DRIVE AGITATORS

## for Heavy Fluids in Open-top 55 Gallon Drums

### Model 31-397

Gear Drive Agitator (with cover)  
(replaced 31-131)

- For open top 55 gallon drums
- Gear drive, 40 RPM
- For heavier fluids such as paints and mastics
- 20:1 Gear reduction

#### Furnished with:

- 1 HP air motor (10 to 14 CFM)
- Two 14-1/2 in. diameter stainless steel paddles with stainless steel shaft
- Zinc Plated Clear Chromate cover (31-124)

**Ref. Part Sheet:** 77-2804

**Speed:** Speed of the air motor is regulated by an air adjusting valve (part no. HAV-500). The speed of the agitator shaft below the reduction gearbox should not run faster than 30 to 40 RPM and a maximum of 150 RPM.

**Air supply:** Air used to operate this unit should come directly from a high pressure source; do not use air that has passed through a regulator. Air supply to the motor should be a minimum of 60 psi gauge pressure.

**Recommended lubricant:** None required.

An air filter/moisture trap is recommended. See *Accessories* section.

### Model 202-55-2

Gear Drive Agitator (with cover)

- For open top 55 gallon drums
- Gear drive, 1.5 HP
- Two Stainless Steel Paddles
- For heavier fluids such as paints and mastics

**Recommended lubricant:** SAE 10W non-detergent oil, 10-20 drops daily.

**Ref. Part Sheet:** 77-2814

### Model 202-55-4

Gear Drive Agitator (with cover)

- For open top 55 gallon drums
- Gear drive, 1.5 HP
- Four Stainless Steel Paddles
- For heavier fluids such as paints and mastics

**Recommended lubricant:** SAE 10W non-detergent oil, 10-20 drops daily.

**Ref. Part Sheet:** 77-2814

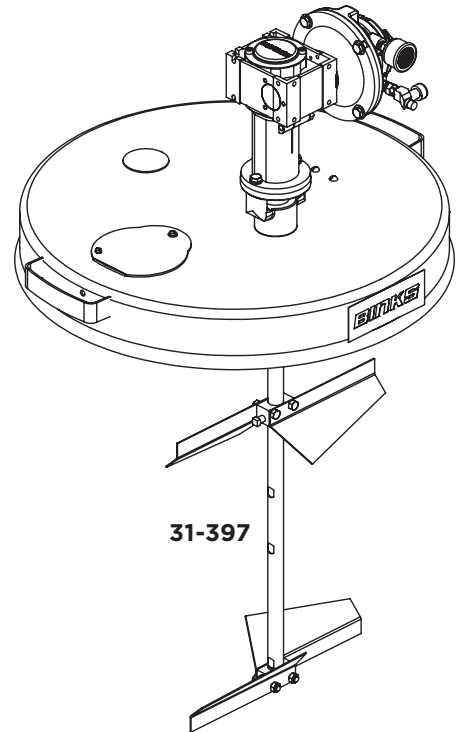

## BINKS GEAR DRIVE AGITATORS

for Heavy Fluids in Open-top 55 Gallon Drums

### SPECIFICATIONS

MODEL NUMBER	31-397	202-55-2	202-55-4
Container Size	Open 55 Gal Drum	Open 55 Gal Drum	Open 55 Gal Drum
Shipping Weight (lbs)	60	75	78
Ref. Part Sheet	77-2991	77-2814	77-2814

### MOTOR SPECIFICATIONS

Air Motor Model	31-418-1	207-12323	207-12323
Gear Box Model	31-416-1	207-12323	207-12323
Drive Type	Gear Drive	Gear Drive	Gear Drive
HP: (Max)	1 HP	1.5 HP	1.5 HP
CFM: (Avg)	10-14 CFM	45 CFM@60 PSI	45 CFM@60 PSI
Air Motor Repair Kit	KK-5001-1A	237-913	237-913
Gear Box Repair Kit	N/A	N/A	N/A

### SHAFT SPECIFICATIONS

Mount	Flange	Flange	Flange
Diameter	1/2" (12.7 MM)	1/2" (12.7 MM)	1/2" (12.7 MM)
Speed (Avg)	40 RPM	300 RPM	300 RPM
Material	Stainless Steel	Stainless Steel	Stainless Steel

### PROPELLER SPECIFICATIONS

Number of Props	2	2	4
Diameter	14"	14"	14"
Material (Type 304)	Stainless Steel	Stainless Steel	Stainless Steel

### COVER SPECIFICATIONS

Part Number	31-124 / 31-426	207-12322	207-12322
Size	55 Gal / 55 Gal	55 Gal	55 Gal
Material	Zinc Plated Steel / Stainless Steel	Zinc Plated Steel	Zinc Plated Steel

*Air motors and gearboxes are lubricated devices. Air motors require daily lubrication either manually or with an automatic lubricator. Failure to lubricate will accelerate wear and void the warranty. Permanent damage will occur to vanes and rotors, and possibly to other components. See recommended manual or automatic lubricators in the Accessories section. Lubricant type: SAE 10W non-detergent oil. Binks Part No. 207-11155-1 (2 oz. bottle) or 207-11155-2 (16 oz. bottle). Safety Data Sheet: SDS-27.*



See Reference Guide (pages 32-35) and Accessories (pages 36-37) for more information

# BINKS AGITATOR GEAR DRIVE UNIT

## for 30, 60 Gallon Pressure Tanks & 55 Gallon Drums

### Model 31-396-1

Agitator Drive

- Air motor drive unit with gear reducer
- 1 HP; 20:1 Ratio; 40 RPM output

**Ref. Part Sheet:** 77-2991

**Speed:** Speed of the air motor is regulated by an air adjusting valve (part no. HAV-500). The speed of the agitator shaft below the reduction gearbox should not run faster than 30 to 40 RPM maximum.

**Air supply:** Air used to operate this unit should come directly from a high pressure source; do not use air that has passed through a regulator. Air supply to the motor should be a minimum of 60 psi gauge pressure. Air consumption is 30 CFM @ 100 psi.

**Recommended lubricant:** None required.

An air filter/moisture trap is recommended. See *Accessories* section.

**Shipping weight:** 20 lbs.

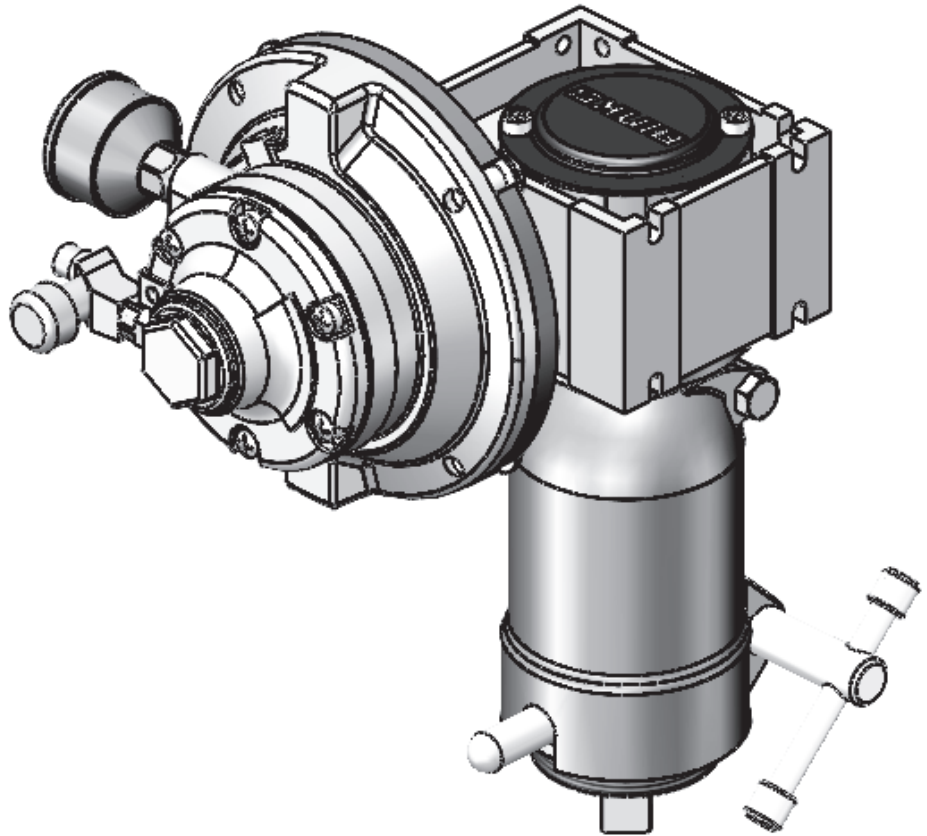

## BINKS AGITATOR GEAR DRIVE UNIT

for 30, 60 Gallon Pressure Tanks & 55 Gallon Drums

### SPECIFICATIONS

MODEL NUMBER	31-396-1
Container Size	30, 55 & 60
Shipping Weight (lbs)	20
Ref. Part Sheet	77-2991

### MOTOR SPECIFICATIONS

Air Motor Model	31-418-1
Gear Box Model	31-416-1
Drive Type	Gear Drive
HP: (Max)	1 HP
CFM: (Max)	30 CFM
Air Motor Repair Kit	KK-5001-1A
Gear Box Repair Kit	N/A

### SHAFT SPECIFICATIONS

Mount	Flange
Diameter	N/A
Speed (Avg)	30-40 RPM
Material	N/A



See Reference Guide (pages 32-35) and Accessories (pages 36-37) for more information

# BINKS QUICK MIXERS

## for Container Sizes of 5 to 55 Gallons

### Model 149-873

Quick Mixer Complete  
(for 5 and 10 gallon containers)

### Model 149-874

Quick Mixer Complete  
(for 55 gallon containers)

### Model 149-365

Mixer only, less motor & handle  
(for 5 and 10 gallon containers)

### Model 149-693

Mixer only, less motor & handle  
(for 55 gallon containers)

- Designed for standard and for extra heavy industrial uses
- All purpose - unsurpassed for paint, resins, chemicals, and slurries

**Ref. Part Sheet:** 77-2826

**Performance:** Explosion-proof direct drive air motors: 1 HP (standard). Implosion-type high shear mixer blades thoroughly mix 5 gallons of paint in less than 60 seconds.

**Rugged:** Stainless steel shaft and impeller. Specially welded stress points makes mixer virtually unbreakable.

**Puncture-proof:** Patented double ring design eliminates damage to container.

**Speed:** The speed of the air motor is regulated by an air adjusting valve (73-159).

**Recommended lubricant:** SAE 10W non-detergent oil, 10-20 drops daily.

**Shipping weight:** 9 lbs. / 10 lbs.



## BINKS QUICK MIXERS

for Container Sizes of 5 to 55 Gallons

### SPECIFICATIONS

MODEL NUMBER	149-873	149-874
Container Size	5 and 10 Gal	55 Gal
Shipping Weight (lbs)	9	10
Ref. Part Sheet	77-2826	77-2826

### MOTOR SPECIFICATIONS

Air Motor Model	83-1922	83-1922
Gear Box Model	N/A	N/A
Drive Type	Direct	Direct
HP: (Max)	1 HP	1 HP
CFM: (Max)	30 CFM@3000 RPM	30 CFM@3000 RPM
Air Motor Repair Kit	6-183	6-183
Gear Box Repair Kit	N/A	N/A

### SHAFT SPECIFICATIONS

Mount	Hand Held	Hand Held
Diameter / Length	1/2" / 21"	1/2" / 40"
Speed: (Max)	3000 RPM	3000 RPM
Material	Stainless Steel	Stainless Steel

### PROPELLER SPECIFICATIONS

Number of Props	1	1
Diameter	5"	5"
Material	Stainless Steel	Stainless Steel

*Air motors and gearboxes are lubricated devices. Air motors require daily lubrication either manually or with an automatic lubricator. Failure to lubricate will accelerate wear and void the warranty. Permanent damage will occur to vanes and rotors, and possibly to other components. See recommended manual or automatic lubricators in the Accessories section. Lubricant type: SAE 10W non-detergent oil. Binks Part No. 207-11155-1 (2 oz. bottle) or 207-11155-2 (16 oz. bottle). Safety Data Sheet: SDS-27.*



See Reference Guide (pages 32-35) and Accessories (pages 36-37) for more information

# BINKS BUNG AGITATOR

## for Closed-top 55 Gallon Drums

### Model 31-296

Heavy Duty Bung Agitator

- Collapsible blades
- 1 HP air motor drive

Binks Bung Agitators are easy-to-use high torque mixers with collapsible blades allowing insertion and extraction through the standard 2-in. bung in closed-top 55 gallon containers. During rotation, centrifugal force causes the blades to open.

Bung agitators are air-motor driven with 32-in. long shafts and mounted with two sets of blades.

**Ref. Part Sheet: 77-2055**

**Speed:** 3000 RPM maximum (regulated by 73-159 air adjusting valve)

**Air supply:** Air supply to the motor should be 60 psi gauge pressure minimum (approximately 10 CFM). An air filter/moisture trap is recommended. See *Accessories* section.

**Recommended lubricant:** SAE 10W non-detergent oil, 10-20 drops daily.

**Shipping weight:** 17 lbs.





## BINKS BUNG AGITATOR

for Closed-top 55 Gallon Drums

### SPECIFICATIONS

Model Number	31-296
Container Size	55 Gal
Shipping Weight (lbs)	17
Ref. Part Sheet	77-2055

### MOTOR SPECIFICATIONS

Air Motor Model	83-2815
Gear Box Model	N/A
Drive Type	Direct
HP: (Max)	1 HP
CFM: (Avg)	10 CFM
Air Motor Repair Kit	6-197
Gear Box Repair Kit	N/A

### SHAFT SPECIFICATIONS

Mount	2" Bung
Diameter	1/2"
Speed (Max)	3000 RPM
Material	Stainless Steel

### PROPELLER SPECIFICATIONS

Number of Props	2
Diameter	3 1/2"
Material	Nickel Plated Steel

*Air motors and gearboxes are lubricated devices. Air motors require daily lubrication either manually or with an automatic lubricator. Failure to lubricate will accelerate wear and void the warranty. Permanent damage will occur to vanes and rotors, and possibly to other components. See recommended manual or automatic lubricators in the Accessories section. Lubricant type: SAE 10W non-detergent oil. Binks Part No. 207-11155-1 (2 oz. bottle) or 207-11155-2 (16 oz. bottle). Safety Data Sheet: SDS-27.*



See Reference Guide (pages 32-35) and Accessories (pages 36-37) for more information

# BINKS C-CLAMP AGITATOR

## for Rim Mounting on Open-top 55 Gallon Containers

### Model 31-120

C-clamp Agitator

- 1 HP air motor drive
- 9-1/2 inch diameter aluminum paddles
- Stainless steel shaft

**Ref. Part Sheet:** 77-1617

**Shaft length:** 32 in.

**Number of propellers:** 2

**Drive type:** Direct drive

**Speed:** 3000 RPM maximum  
(regulated by 73-159 air adjusting valve.)

**Recommended lubricant:** SAE 10W  
non-detergent oil, 10-20 drops daily.

**Air supply:** Air supply to the motor  
should be 60 psi gauge pressure  
minimum.

An air filter/moisture trap is  
recommended. See *Accessories*  
section.



## BINKS C-CLAMP AGITATOR

for Rim Mounting on Open-top 55 Gallon Containers

### SPECIFICATIONS

MODEL NUMBER	31-120
Container Size	55 Gal
Shipping Weight (lbs)	16
Ref. Part Sheet	77-1617

### MOTOR SPECIFICATIONS

Air Motor Model	37-384
Gear Box Model	N/A
Drive Type	Direct
HP: (Max)	1 3/4 HP
CFM: (Max)	78 CFM
Air Motor Repair Kit	6-197
Gear Box Repair Kit	N/A

### SHAFT SPECIFICATIONS

Mount	C Clamp Rim
Diameter	5/8"
Speed (Max)	3000 RPM
Material (Type 303)	Stainless Steel

### PROPELLER SPECIFICATIONS

Number of Props	2
Diameter	9 1/2"
Material	Aluminum

*Air motors and gearboxes are lubricated devices. Air motors require daily lubrication either manually or with an automatic lubricator. Failure to lubricate will accelerate wear and void the warranty. Permanent damage will occur to vanes and rotors, and possibly to other components. See recommended manual or automatic lubricators in the Accessories section. Lubricant type: SAE 10W non-detergent oil. Binks Part No. 207-11155-1 (2 oz. bottle) or 207-11155-2 (16 oz. bottle). Safety Data Sheet: SDS-27.*



See Reference Guide (pages 32-35) and Accessories (pages 36-37) for more information

# BINKS AGITATORS

## for Open-top 5 Gallon & 55 Gallon Containers

**Model 843000**  
Agitator (5 gallon)  
(agitator assembly only)

**Model 843001**  
Agitator (55 gallon)  
(agitator assembly only)

**Model 874502**  
Pail Cover (5 gallon)  
(stainless steel pail cover only)

**Model 874506**  
Drum Cover (55 gallon)  
(stainless steel drum cover only)

■ Agitator assemblies and drum covers sold separately

**Recommended lubricant:** SAE 10W non-detergent oil, 10-20 drops daily.



874502

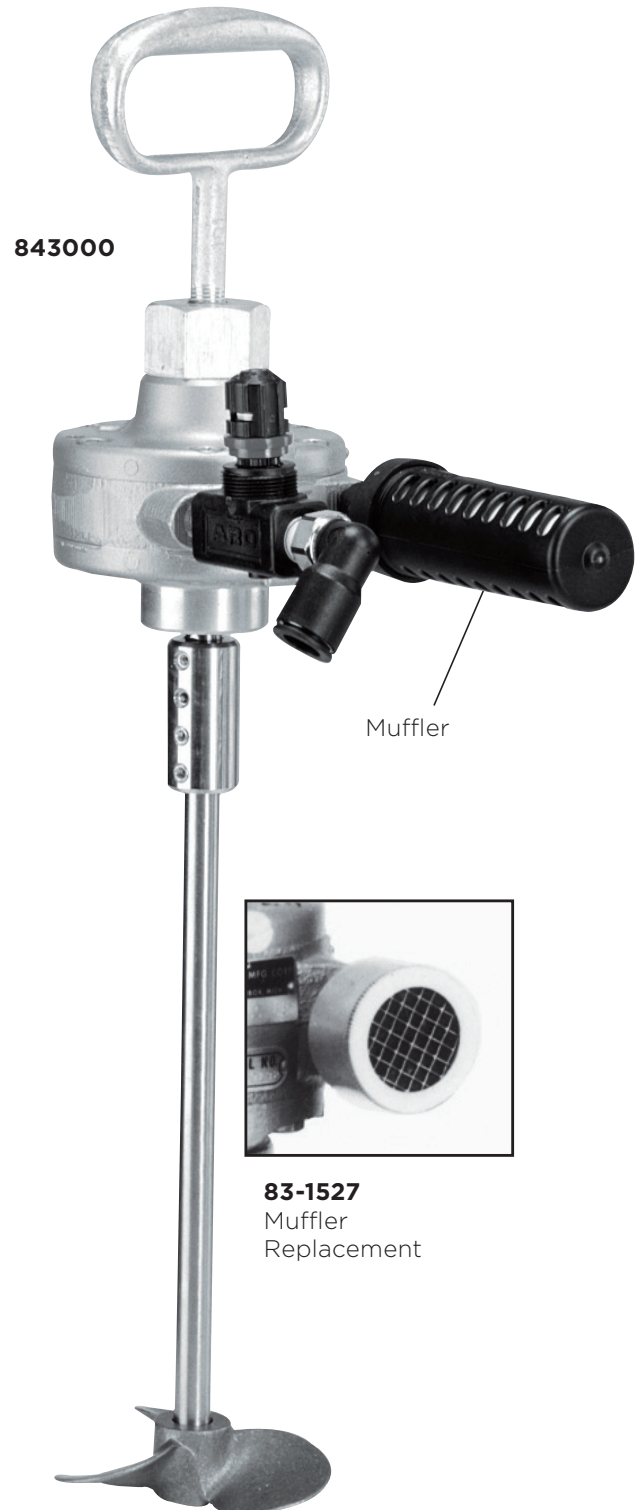

843000

Muffler

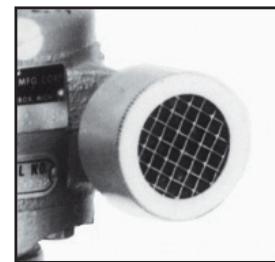

**83-1527**  
Muffler  
Replacement

## BINKS AGITATORS

for Open-top 5 Gallon & 55 Gallon Containers

### SPECIFICATIONS

MODEL NUMBER	843000	843001
Container Size	5 Gal	55 Gal
Shipping Weight (lbs)	11	11
Ref. Part Sheet	843000	843001

### MOTOR SPECIFICATIONS

Air Motor Model	QMS-428	QMS-428
Gear Box Model	N/A	N/A
Drive Type	Direct	Direct
HP: (Max)	1 HP	1 HP
CFM: (Max)	30 CFM	30 CFM
Air Motor Repair Kit	KK-5001-1A	KK-5001-1A
Gear Box Repair Kit	N/A	N/A

### SHAFT SPECIFICATIONS

Mount	Hub	Hub
Diameter / Length	1/2"	1/2"
Speed: (Max)	300-3000 RPM	300-3000 Rpm
Material (Type 316)	Stainless Steel	Stainless Steel

### PROPELLER SPECIFICATIONS

Number of Props	1	2
Diameter	3"	3"
Material	Stainless Steel	Stainless Steel

### COVER SPECIFICATIONS

Part Number	874502	874506
Size	5 Gal	55 Gal
Material	Stainless Steel	Stainless Steel

*Air motors and gearboxes are lubricated devices. Air motors require daily lubrication either manually or with an automatic lubricator. Failure to lubricate will accelerate wear and void the warranty. Permanent damage will occur to vanes and rotors, and possibly to other components. See recommended manual or automatic lubricators in the Accessories section. Lubricant type: SAE 10W non-detergent oil. Binks Part No. 207-11155-1 (2 oz. bottle) or 207-11155-2 (16 oz. bottle). Safety Data Sheet: SDS-27.*



See Reference Guide (pages 32-35) and Accessories (pages 36-37) for more information

# BINKS DIRECT DRIVE AGITATORS

## for 2 Gallon Pressure Tanks (2.8 gallon actual capacity)

### Model QMG-416

Direct Drive Agitator for use with 183G series (galvanized)

### Model QMS-430

Direct Drive Agitator for use with 183S series (stainless steel)

■ **Stainless steel and galvanized agitator assemblies are interchangeable**

Air-powered direct drive agitator assembly with 1 HP air motor and a three-bladed propeller to keep materials mixed in suspension, even high solids. Agitator assemblies come complete with HAV-500 air adjusting valve and HA-57011 air hose assembly.

**Service Bulletin Number: 77-2990**

**Model QMG-416:** Used with 183G-211, -221, -231, -241 series

**Model QMS-430:** Used with 183S-211, -221, -231, -241 series

**Recommended lubricant:** SAE 10W non-detergent oil, 10-20 drops daily.

**Shipping weight:** 8 lbs.

An air filter/moisture trap is recommended. See *Accessories* section.

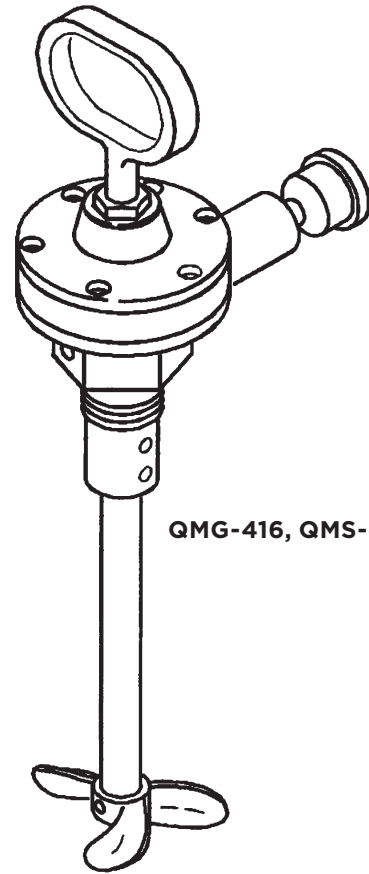

SERIES	ORDER
83Z	Model PT-427 air motor/adaptor Model PT-419 shaft assembly
83C	Model PT-418 air motor/adaptor Model PT-428 shaft assembly
183G (2 gallon)	Model QMG-416 complete air motor & shaft assembly
183S (2 gallon)	Model QMS-430 complete air motor & shaft assembly

### Model QMG/QMS

Agitators

**Service Bulletin Number: 77-2990**

**Shipping weight:** 1 lb.

See *Accessories* section.

See page 24 for air motor drive assembly.

**Stainless steel:** QMS-431 (2 gallon), QMS-432 (5 gallon), QMS-433 (10 gallon), QMS-434 (15 gallon)

**Plated steel:** QMG-417 (2 gallon), QMG-418 (5 gallon), QMG-419 (10 gallon), QMG-420 (15 gallon)

CE versions available, contact your Carlisle Fluid Technologies representative:  
QMS-430-CE, QMS-431-CE, QMS-433-CE, QMS-434-CE, PT-418-CE, PT-419-CE, PT-427-CE, PT-428-CE

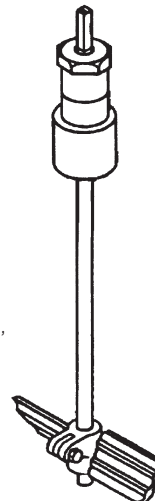

**BINKS DIRECT DRIVE AGITATORS**  
for 2 Gallon Pressure Tanks

*SPECIFICATIONS*

MODEL NUMBER	QMG-416	QMS-430	QMG-429
Container Size	2 Gal Tank	2 Gal Tank	2 Gal Tank
Shipping Weight (lbs)	8	8	5
Ref. Part Sheet	77-2990	77-2990	77-2990

*MOTOR SPECIFICATIONS*

Air Motor Model	QMG-429	QMG-429	QMG-429
Gear Box Model	N/A	N/A	N/A
Drive Type	Direct Drive	Direct Drive	Direct Drive
HP: (Max)	1 HP	1 HP	1 HP
CFM: (Max)	30 CFM	30 CFM	30 CFM
Air Motor Repair Kit	KK-5001-1A	KK-5001-1A	KK-5001-1A
Gear Box Repair Kit	N/A	N/A	N/A

*SHAFT SPECIFICATIONS*

Mount	Lid / Tank	Lid / Tank	Lid / Tank
Diameter	5/8"	5/8"	N/A
Speed (Max)	3000 RPM	3000 RPM	3000 RPM
Material	Plated Steel	Stainless Steel	N/A

*PROPELLER SPECIFICATIONS*

Number of Props	1	1	N/A
Diameter	3"	6 3/4"	N/A
Material	Glass Filled Nylon	Glass Filled Nylon	N/A



# BINKS GEAR REDUCED DRIVE AGITATORS

for Galvanized & Stainless Steel Pressure Tanks

## Model QS-5012-1

Indirect Air Motor Drive  
(183G and 183S Series)

### 183 Series

## Model QS-5012-1

Gear Reduced Air Motor Drive

For 2-, 5-, 10- and 15-gallon 183G and 183S Series.

Designed to drive agitators. Standard duty, smooth running with gear reducer. 1 HP; 20:1 Ratio; 120 RPM maximum.

Includes air adjusting valve, fittings, and hose for connection to air supply on tank lid. An air filter/moisture trap is recommended. See *Accessories* section.

**Ref. Part Sheet:** 77-2990

**Recommended lubricant:** None required.

**Shipping weight:** 11 lbs.

## Model QMG/QMS

Agitators

**Service Bulletin Number:** 77-2990

**Shipping weight:** 1 lb.

See *Accessories* section.

See page 24 for air motor drive assembly.

**Stainless steel:** QMS-431 (2 gallon), QMS-432 (5 gallon), QMS-433 (10 gallon), QMS-434 (15 gallon)

**Plated steel:** QMG-417 (2 gallon), QMG-418 (5 gallon), QMG-419 (10 gallon), QMG-420 (15 gallon)

CE versions available, contact your Carlisle Fluid Technologies representative: QMS-430-CE, QMS-431-CE, QMS-433-CE, QMS-434-CE, PT-418-CE, PT-419-CE, PT-427-CE, PT-428-CE

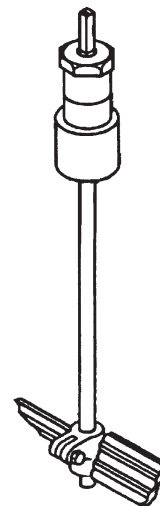
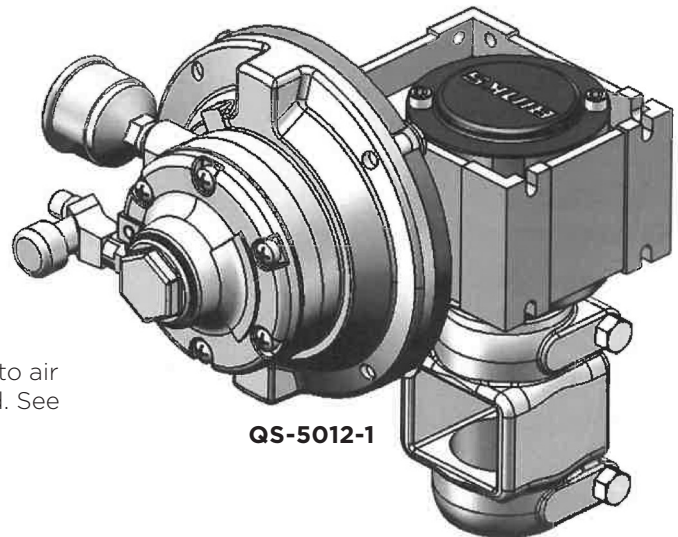



**BINKS GEAR REDUCED DRIVE AGITATORS**  
for Galvanized, Zinc Plated & Stainless Steel Pressure Tanks

*SPECIFICATIONS*

MODEL NUMBER	QS-5012-1	QMG-416	QMS-430
Container Size	N/A	2 Gal	2 Gal
Shipping Weight (lbs)	11	8	8
Ref. Part Sheet	77-2990	77-2990	77-2990

*MOTOR SPECIFICATIONS*

Air Motor Model	31-418-1	N/A	N/A
Gear Box Model	31-416-1	N/A	N/A
Drive Type	Gear Reduced	N/A	N/A
HP: (Max)	1 HP	N/A	N/A
CFM: (Max)	30 CFM	N/A	N/A
Air Motor Repair Kit	KK-5001-1A	N/A	N/A
Gear Box Repair Kit	N/A	N/A	N/A

*SHAFT SPECIFICATIONS*

Mount	Lid Mount	Lid Mount	Lid Mount
Diameter	N/A	5/8"	5/8"
Speed (Max)	120 RPM	120 RPM	120 RPM
Material	N/A	Plated Steel	Stainless Steel

*PROPELLER SPECIFICATIONS*

Number of Props	N/A	1	1
Diameter	N/A	6 3/4"	6 3/4"
Material	N/A	Glass Filled Nylon	Glass Filled Nylon



# BINKS HEAVY DUTY AGITATOR DRIVE

for 30 and 60 gallon tanks

## Model 83-2476

Heavy Duty Agitator Drive  
(30 & 60 gallon tanks only)

- Air motor drive unit with gear reducer
- 1 3/4 HP; 30:1 Ratio
- 15 to 50 RPM output

**Ref. Part Sheet:** 77-1622

**Speed:** Speed of the air motor is regulated by an air adjusting valve (part no.73-159). Propeller below the reduction gearbox should never be run faster than 100 RPM maximum.

**Air supply:** Air supply to the motor should be 60 psi gauge pressure minimum.

**Recommended lubricant:** SAE 10W non-detergent oil, 10-20 drops daily.

An air filter/moisture trap is recommended. See *Accessories* section.

**Shipping weight:** 20 lbs.



83-2476



## BINKS HEAVY DUTY AGITATOR DRIVE for 30 and 60 gallon tanks

### SPECIFICATIONS

MODEL NUMBER	83-2476
Container Size	30 & 60 Gal
Shipping Weight (lbs)	20
Ref. Part Sheet	77-1622 / 77-1833

### MOTOR SPECIFICATIONS

Air Motor Model	37-472
Gear Box Model	37-471
Drive Type	Gear Reduced
HP: (Max)	1 3/4 HP
CFM: (Max)	78 CFM
Air Motor Repair Kit	6-197
Gear Box Repair Kit	Individual Parts

### SHAFT SPECIFICATIONS

Mount	Lid Mount
Diameter	N/A
Speed (Max)	100 RPM
Material	N/A

*Air motors and gearboxes are lubricated devices. Air motors require daily lubrication either manually or with an automatic lubricator. Failure to lubricate will accelerate wear and void the warranty. Permanent damage will occur to vanes and rotors, and possibly to other components. See recommended manual or automatic lubricators in the Accessories section. Lubricant type: SAE 10W non-detergent oil. Binks Part No. 207-11155-1 (2 oz. bottle) or 207-11155-2 (16 oz. bottle). Safety Data Sheet: SDS-27.*



See Reference Guide (pages 32-35) and Accessories (pages 36-37) for more information

# BINKS AGITATORS & COVERS

## for Open-top 55 Gallon Drums and Drums with Built-in Agitators

**Model 31-124** Drum Cover

**Model 874506** Stainless Steel Drum Cover

**Model QS-5003-1** Paint Drum Agitator Drive

**Model 41-9000** Elevator

### Model 31-124

Drum Cover

55 Gallon, 24 inch diameter drum cover includes three holes for additional components. Used with 31-129 stainless steel agitator with cover and 31-397 55 gallon plated steel agitator.

**Ref. Part Sheet:** 77-1481

### Model 874506

Stainless Steel Drum Cover (not shown)

55 Gallon stainless steel drum cover for use with 1/2 inch diaphragm pumps and bung mounted piston pumps.

**Shipping weight:** 23 lbs.

### Model QS-5003-1

Paint Drum Agitator and Gear Drive

For use with paint drums having built-in agitators. Powerful 1 HP variable speed air motor, 300-3000 RPM.

Requires 5 to 8 CFM of air for 50 RPM of agitator; adjustable from 10 RPM up. 1/4 inch NPS(m) air connection.

Includes couplings to fit 7/16 inch and 1/2 inch agitator shafts. Mounting adapter fits both 1-1/2 inch and 2 inch threads.

**Recommended lubricant:** None required.

An air filter/moisture trap is recommended. See *Accessories* section.

**Ref. Part Sheet:** 77-2991

**Shipping weight:** 15 lbs.

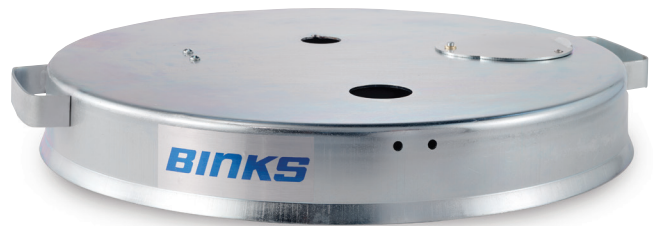

31-124

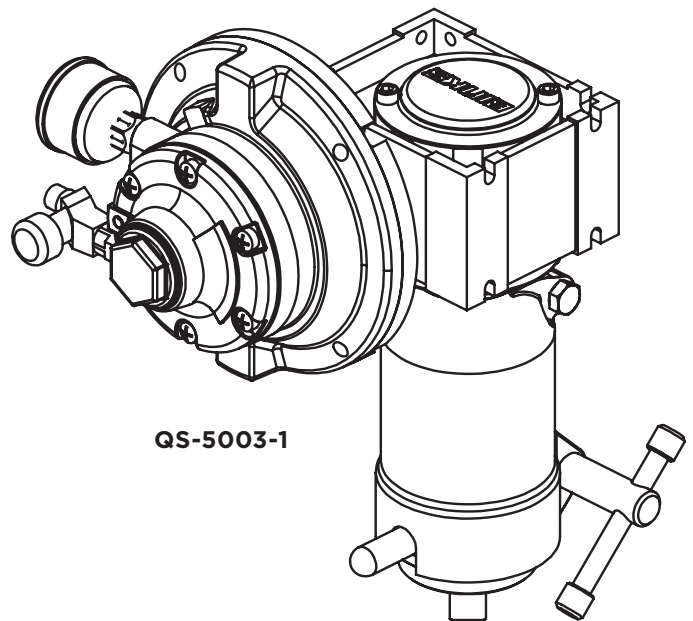

QS-5003-1



## BINKS AGITATORS & COVERS

for Open-top 55 Gallon Drums and Drums with Built-in Agitators

### SPECIFICATIONS

**MODEL NUMBER** / **QS-5003-1**

Container Size	55 Gal
Shipping Weight (lbs)	15
Ref. Part Sheet	77-2991

### MOTOR SPECIFICATIONS

Air Motor Model	31-418-1
Gear Box Model	31-391-1
Drive Type	Gear Reduced
HP: (Max)	1 HP
CFM: (Max)	30 CFM
Air Motor Repair Kit	KK-5001-1A
Gear Box Repair Kit	N/A

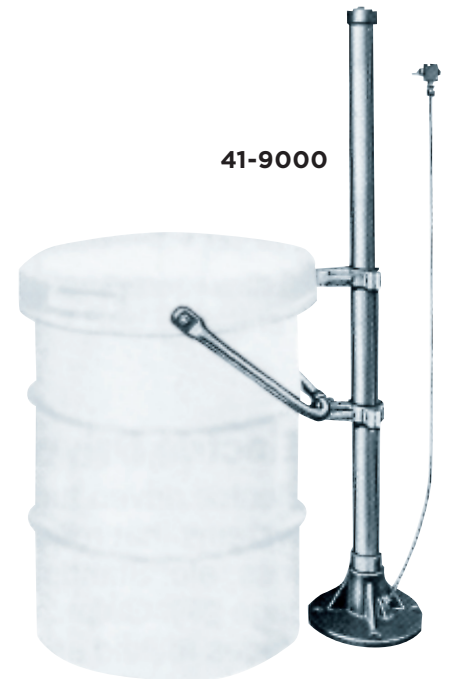

### Model 41-9000 Elevator

Single post elevator for lifting 55 gallon cover-mounted pump and agitator units.

Can support up to 395 lbs. @ 100 psi.

**Ref. Part Sheet: 77-1392**

**Shipping weight: 68 lbs.**



See Reference Guide (pages 32-35) and Accessories (pages 36-37) for more information

# BINKS AGITATORS, DRIVES & COVERS

## for 5 Gallon Containers

### Model 41-3306

Agitator & Drive assembly

### Model 41-3312

Agitator & Drive assembly

### Model 41-3312-S

Agitator & Drive assembly

### Model 31-425

Agitator, Drive & Cover assembly

- Furnished as an agitator/drive assembly, or as an agitator/drive/cover assembly
- Agitator and drive assembly only, standard

**Ref. Part Sheet:** 77-1474

**Speed:** Speed of propeller shaft is determined by fluid, 3000 RPM maximum.

**Air supply:** Air supply to the motor should be 60 psi gauge pressure minimum.

**Recommended lubricant:** SAE 10W non-detergent oil, 10-20 drops daily.

An air filter/moisture trap is recommended. See *Accessories* section.

### Model 41-718810

Cover

- Cover for open-top 5-gallon container
- Stainless steel - Gemini II pumps

**Ref. Part Sheet:** 77-3030

**Shipping weight:** 5-1/2 lbs.



**31-425**  
agitator, drive and  
cover assembly

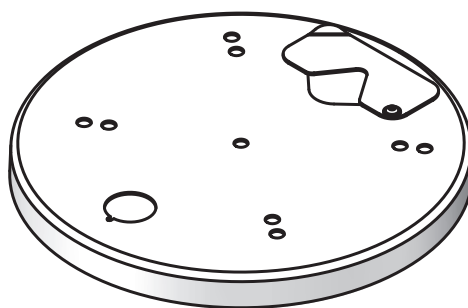

**41-718810**



**41-3312**  
agitator and  
drive assembly



**BINKS AGITATORS, DRIVES & COVERS**  
for 5 Gallon Containers

**SPECIFICATIONS**

MODEL NUMBER	41-3306	41-3312	41-3312-S	31-425
Container Size	5 Gal	5 Gal	5 Gal	5 Gal
Shipping Weight (lbs)	4	4	4	4
Ref. Part Sheet	77-1474	77-1474	77-1474	77-1474

**MOTOR SPECIFICATIONS**

Air Motor Model	37-478	37-478	37-478	37-478
Gear Box Model	N/A	N/A	N/A	N/A
Drive Type	Direct	Direct	Direct	Direct
HP: (Max)	1/4 HP	1/4 HP	1/4 HP	1/4 HP
CFM: (Max)	10-14 CFM	10-14 CFM	10-14 CFM	10-14 CFM
Air Motor Repair Kit	37-478	37-478	37-478	37-478
Gear Box Repair Kit	N/A	N/A	N/A	N/A

**SHAFT SPECIFICATIONS**

Mount	Lid / Cover	Lid / Cover	Lid / Cover	Lid / Cover
Diameter	3/8"	3/8"	3/8"	3/8"
Speed	3000 RPM	3000 RPM	3000 RPM	3000 RPM
Material	Zinc Plated Clear Chromate	Stainless Steel	Stainless Steel	Stainless Steel

**PROPELLER SPECIFICATIONS**

Number of Props	1	1	1	1
Diameter	3 1/8"	3 1/8"	3 1/8"	3 1/8"
Material	Aluminum	Stainless Steel	Stainless Steel	Stainless Steel

**COVER SPECIFICATIONS**

Part Number	N/A	N/A	N/A	31-428
Size	N/A	N/A	N/A	5 Gal
Material	N/A	N/A	N/A	Stainless Steel

*Air motors and gearboxes are lubricated devices. Air motors require daily lubrication either manually or with an automatic lubricator. Failure to lubricate will accelerate wear and void the warranty. Permanent damage will occur to vanes and rotors, and possibly to other components. See recommended manual or automatic lubricators in the Accessories section. Lubricant type: SAE 10W non-detergent oil. Binks Part No. 207-11155-1 (2 oz. bottle) or 207-11155-2 (16 oz. bottle). Safety Data Sheet: SDS-27.*



See Reference Guide (pages 32-35) and Accessories (pages 36-37) for more information

# AGITATORS

## Equipment Reference Guide

AGITATORS, QUICK MIXERS, GEAR DRIVES AND ACCESSORIES

Chart continues on next page ►

PART NUMBER	DESCRIPTION	OPTIONAL / COVER	CONTAINER SIZE	AIR MOTOR OR AIR MOTOR AND GEARBOX	AIR MOTOR HP	NUMBER OF PROPELLARS	PROPELLAR AND SHAFT MATERIAL
<b>202-55-2</b>	Air Motor / Agitator	207-12322	55 Gallon	207-12323 A/M	1.5 HP	2	Stainless Steel
<b>202-55-4</b>	Air Motor / Agitator	207-12322	55 Gallon	207-12323 A/M	1.5 HP	4	Stainless Steel
<b>31-133-CE</b>	Agitator for 5 Gallon Pail, Direct Drive	41-3205; Included	5 Gallon	37-478 A/M	.25 HP	1	Stainless Steel
<b>41-3312</b> Replaces 41-3312-CE	Direct Drive, W/O Cover,	N/A	5 Gallon	37-478 A/M	.25 HP	1	Stainless Steel
<b>41-3312-S</b>	Direct Drive, W/O Cover,	N/A	5 Gallon	37-478 A/M	.25 HP	1	Stainless Steel
<b>41-3306</b>	Direct Drive, W/O Cover,	N/A	5 Gallon	37-478 A/M	.25 HP	1	Aluminum
<b>31-296</b> Replaces 31-295	Bung Agitator	N/A	55 Gallon	83-2815 A/M	1 HP	2	Plated Steel
<b>41-3300</b>	55 Gallon Direct Drive Agitator Assy.	N/A	55 Gallon	83-1922 / A/M	1 HP	2	Stn. Stl. Shaft / Aluminum Paddles
<b>41-3304</b>	55 Gallon Direct Drive Agitator Assy.	31-124	55 Gallon	83-1922 / A/M	1 HP	2	Stainless Steel
<b>41-3305</b>	30 Gallon Agitator Assy. Less Drive	N/A	30 Gallon	N/A	N/A	2	Stainless Steel
<b>41-3306</b>	5 Gallon Agitator Assembly	N/A	5 Gallon	37-478 A/M	.25 HP	1	Stainless Steel
<b>31-120</b>	55 Gallon C Clamp Rim Mount Style Agitator Assembly	N/A	55 Gallon	37-384 A/M	1 HP	2	Stainless Steel Shaft and 9.5" aluminum paddles
<b>31-129</b> Replaces 31-128	55 Gallon Direct Drive Agitator Assy. w/cover	31-124	55 Gallon	41-3304 Assy. 83-1922 A/M	1 HP	2	Stainless Steel
<b>31-393-1</b>	Agitator Drive Assembly	N/A	55 Gallon	31-418-1 A/M	1 HP	N/A	N/A
<b>31-397</b> Replaces 31-131	55 Gallon Gear Driven Agitator assy w/cover	31-124	55 Gallon	31-401-1 A/M & Gearbox	1 HP	2	Stainless Steel
<b>31-394</b> Replaces 31-114	55 Gallon Gear Drive Assy. For 55 gallon drums with built in agitator	N/A	55 Gallon	31-393-1 A/M & Gearbox	1 HP	N/A	N/A
<b>31-400</b> Replaces 41-3311	Gear Drive Agitator Assy.	Not Included	30 Gallon	31-401-1 A/M & Gearbox	1 HP	2	Stainless Steel
<b>31-401-1</b> Replaces 31-401 and 31-121	Gear Drive Agitator Assy.	Not Included	2-15 Gallon Gear Drive Agitators	31-391-1 A/M & Gearbox	1 HP	N/A	N/A
<b>80-611</b>	SG-2 Agitator Assy. (Oscillating)	Not Included	2 Qt. SG-2 Cups	80-611 A/M	.25 HP	1	Stainless Steel
<b>80-452</b>	SG-2 Plus Agitator Assy. (Rotary)	Not Included	2 Qt. SG-2 Plus Cups	37-478 A/M	.5 HP	1	Stainless Steel
<b>83-2476</b>	Air Motor Gear Drive Assy.	N/A	30 & 60 Gallon Tanks	37-471 Gearbox and 37-472 A/M	1.75 HP	N/A	N/A
<b>QS-5001-1</b> Replaces QS-5001	Air Motor and Gearbox Assy.	Not Included	2-15 Gallon Gear Drive Agitators	31-418-1 A/M 31-391-1 A/M & Gearbox	1 HP	N/A	N/A
<b>QS-5003-1</b> Replaces QS-5003	Air Motor and Gearbox Assy.	Not Included	For 55 Gallon Drums with built in Agitators	31-418-1 A/M 31-391-1 A/M & Gearbox	1 HP	N/A	N/A



# AGITATORS

## Equipment Reference Guide

### AGITATORS, QUICK MIXERS, GEAR DRIVES AND ACCESSORIES

PART NUMBER	GEARBOX ASSEMBLY	GEARBOX RATIO	AIR MOTOR OR GEARBOX REPAIR KIT	SHIPPING WEIGHT	SERVICE MANUAL	MISC. NOTES
<b>202-55-2</b>	207-12323-2	10:1	237-913	75 lbs.	77-2814	Lid includes 2 ea, 2" bung plugs. Also includes 207-10858 oiler and HAV-500 air adj. valve
<b>202-55-4</b>	207-12323-2	10:1	237-913	78 lbs.	77-2814	Lid includes 2 ea, 2" bung plugs. Also includes 207-10858 oiler and HAV-500 air adj. valve
<b>31-133-CE</b>	N/A	N/A	6-196	12 lbs.	77-2877	CE Approved. Includes 73-159 air adj. valve and 71-1109 13" air hose and a 20-2002 1/8" hex wrench
<b>41-3312</b> Replaces 41-3312-CE	N/A	N/A	6-196	4 lbs.	77-1474	13.50" long shaft. Includes a 73-159 air adj. valve and a 71-1109 13" air hose
<b>41-3312-S</b>	N/A	N/A	6-196	4 lbs.	77-1474	12" long shaft. Includes a 73-159 air adj. valve and a 71-1112 16.50" air hose
<b>41-3306</b>	N/A	N/A	6-196	4 lbs.	77-1474	13.50" long shaft. Includes a 73-159 air adj. valve and 41-646 muffler. Also includes a 20-2002 1/8" hex wrench
<b>31-296</b> Replaces 31-295	N/A	N/A	6-197	17 lbs.	77-2055	32" long shaft. Includes a 73-159 air adj. valve and a 83-1527 muffler
<b>41-3300</b>	N/A	N/A	6-183	12 Lbs.	77-1390	32" long shaft. Includes a 73-159 air adj. valve and an 83-1527 muffler
<b>41-3304</b>	N/A	N/A	6-183	13 lbs.	77-1390	32" long shaft. Includes a 73-159 air adj. valve and an 83-1527 muffler
<b>41-3305</b>	83-2114 Stuffing Box Assy.	N/A	83-2111-K4	10 lbs.	77-2991	35.25" long shaft
<b>41-3306</b>	N/A	N/A	6-196	4 lbs.	77-1474	13.5" long shaft
<b>31-120</b>	N/A	N/A	6-197	16 lbs.	77-1617	Includes 73-159 air adj. valve and an 83-1527 muffler assy. 32" long shaft
<b>31-129</b> Replaces 31-128	N/A	N/A	6-183	32 lbs.	77-1390	32" long shaft. Includes a 73-159 air adj. valve and an 83-1527 muffler
<b>31-393-1</b>	31-391-1	20:1	KK-5001-1A	18 lbs.	77-2991	Includes muffler kit, HAV-500 air valve kit
<b>31-397</b> Replaces 31-131	31-391-1 A/M & Gearbox Assy.	20:1	KK-5001-1A	60 lbs.	77-2991	32" long shaft. Includes 350-401 muffler and HAV-500 air adj. valve.
<b>31-394</b> Replaces 31-114	31-393-1	20:1	KK-5001-1A	28 lbs.	77-2991	Comes with 3/8, 7/16, 1/2 and 5/8 " couplings. Also includes 350-401 muffler and HAV-500 air adj. valve
<b>31-400</b> Replaces 41-3311	41-3305	20:1	KK-5001-1A	31 lbs.	77-2991	32" long shaft. Includes 31-432 muffler and HAV-500 air adj. valve
<b>31-401-1</b> Replaces 31-401 and 31-121	N/A	20:1	KK-5001-1A	20 lbs.	77-2991	Includes 31-432 muffler and HAV-500 air adj. valve
<b>80-611</b>	N/A	N/A	80-458 Seal	5 lbs.	77-2842	Includes 41-646 muffler. Used on 80-601
<b>80-452</b>	N/A	N/A	80-458 Seal	5 lbs.	77-2842, 77-2843	Includes 41-646 muffler. Used on 80-651
<b>83-2476</b>	37-471	30:1	6-197 A/M kit	20 lbs.	77-1622 / 77-1833	Includes 73-159 air adj. valve, 83-1527 muffler and 71-1111 air hose assy.
<b>QS-5001-1</b> Replaces QS-5001	N/A	20:1	KK-5001-1A	19 lbs.	77-2992	Includes fittings, HAV-500 air adj. valve, 350-401 muffler and QS-70-2 air motor support
<b>QS-5003-1</b> Replaces QS-5003	N/A	20:1	KK-5001-1A	15 lbs.	77-2991	Includes 31-432 muffler and HAV-500 air adj. valve. Also includes a QS-238 support assy., a QS-240 and QS-242 1/2" and 7/16" driver

# AGITATORS

## Equipment Selection Guide

### AGITATORS, QUICK MIXERS, GEAR DRIVES AND ACCESSORIES

Chart continues on next page ►

PART NUMBER	DESCRIPTION	OPTIONAL / COVER	CONTAINER SIZE	AIR MOTOR OR AIR MOTOR AND GEARBOX	AIR MOTOR HP	NUMBER OF PROPELLARS	PROPELLAR AND SHAFT MATERIAL
<b>QS-5012-1</b> Replaces QS-5012	Air Motor and Gearbox Assy.	Not Included	For 5, 10 and 15 Gallon Tanks	31-391-1	1 HP	N/A	N/A
<b>149-365</b>							
<b>149-873</b> Replaces 149-872	5 Gallon Quick Mixer	N/A	5-10 Gallon Containers	149-735	1 HP	1	149-365
<b>149-873</b>							
<b>149-874</b>	55 Gallon Quick Mixer	N/A	55 Gallon Containers	149-735	1 HP	1	149-693

### AGITATORS

Chart continues on next page ►

PART NUMBER	DESCRIPTION	OPTIONAL / COVER	CONTAINER SIZE	AIR MOTOR OR AIR MOTOR AND GEARBOX	AIR MOTOR HP	NUMBER OF PROPELLARS	PROPELLAR AND SHAFT MATERIAL
<b>QMG-416</b>	Direct Drive Agitator	N/A	2 Gallon Pressure Tanks	QMG-429	1 HP	1	Plated steel
<b>QMG-417</b>	Gear Reduced Drive	N/A	2 Gallon Pressure Tanks	N/A	N/A	1	Plated steel
<b>QMG-418</b>	Gear Reduced Drive	N/A	5 Gallon Pressure Tanks	N/A	N/A	1	Plated steel
<b>QMG-419</b>	Gear Reduced Drive	N/A	10 Gallon Pressure Tanks	N/A	N/A	1	Plated steel
<b>QMG-420</b>	Gear Reduced Drive	N/A	15 Gallon Pressure Tanks	N/A	N/A	2	Plated steel
<b>QMS-430</b>	Direct Drive Agitator	N/A	2 Gallon Pressure Tanks	QMS-428	1 HP	1	Stainless Steel
<b>QMS-431</b>	Gear Reduced Drive	N/A	2 Gallon Pressure Tanks	N/A	N/A	1	Stainless Steel
<b>QMS-432</b>	Gear Reduced Drive	N/A	5 Gallon Pressure Tanks	N/A	N/A	1	Stainless Steel
<b>QMS-433</b>	Gear Reduced Drive	N/A	10 Gallon Pressure Tanks	N/A	N/A	1	Stainless Steel
<b>QMS-434</b>	Gear Reduced Drive	N/A	15 Gallon Pressure Tanks	N/A	N/A	2	Stainless Steel
<b>31-129</b>	55 Gallon Direct Drive Agitator Assy.	31-124	55 Gallon	83-1922	1 HP	2	Stainless Steel
<b>31-396-1</b> Replaces 31-396 and 31-116	Gear Reduced Drive	N/A	30 and 60 Gallon	31-418-1 A/M 31-416-1 Gearbox	1 HP	N/A	N/A
<b>31-425</b> Replaces 31-133	Agitator and 5 Gallon Lid Assembly with Handle	31-428	5Gallon	37-478	.25 HP	1	Stainless Steel
<b>843000</b>	5 Gallon Pail Agitator Assembly	874502	5 Gallon	QMS-428	1 HP	1	Stainless Steel
<b>843001</b>	55 Gallon Drum Agitator Assembly	874506	55 Gallon	QMS-428	1 HP	2	Stainless Steel

### GEAR REDUCERS / ELEVATORS

Chart continues on next page ►

PART NUMBER	DESCRIPTION	OPTIONAL / COVER	CONTAINER SIZE	AIR MOTOR OR AIR MOTOR AND GEARBOX	AIR MOTOR HP	NUMBER OF PROPELLARS	PROPELLAR AND SHAFT MATERIAL
<b>31-391-1</b> Replaces 31-391	Agitator Drive Unit	N/A	2-15 Gallon Tanks	31-418 A/M 31-416-1 Gearbox	1 HP	N/A	N/A
<b>31-393-1</b>	Agitator Drive Unit for 31-394	N/A	Open Top 55 Gallon Drives	31-418 A/M 31-416-1 Gearbox	1 HP	N/A	N/A
<b>41-9000</b>	Single Post Drum Elevator	N/A	55 Gallon	N/A	N/A	N/A	N/A

# AGITATORS

## Equipment Selection Guide

### AGITATORS, QUICK MIXERS, GEAR DRIVES AND ACCESSORIES

PART NUMBER	GEARBOX ASSEMBLY	GEARBOX RATIO	AIR MOTOR OR GEARBOX REPAIR KIT	SHIPPING WEIGHT	SERVICE MANUAL	MISC. NOTES
<b>QS-5012-1</b> Replaces QS-5012	N/A	20:1	KK-5001-1	11 lbs.	77-2990	Includes QMS-35 support, HAV-500 air adj. valve and 31-432 muffler
<b>149-365</b>						
<b>149-873</b> Replaces 149-872	N/A	N/A	6-183	9 lbs.	77-2826	149-735, Air motor and handle
<b>149-873</b>						
<b>149-874</b>	N/A	N/A	6-183	10 lbs.	77-2826	149-735, Air motor and handle

### AGITATORS

PART NUMBER	GEARBOX ASSEMBLY	GEARBOX RATIO	AIR MOTOR OR GEARBOX REPAIR KIT	SHIPPING WEIGHT	SERVICE MANUAL	MISC. NOTES
<b>QMG-416</b>	N/A	N/A	KK-5001-1	8 lbs.	SBBI-19-087 77-2995	Includes QN-97 handle, HAV-500 air adj. valve and HA-57011 air hose
<b>QMG-417</b>	N/A	N/A	N/A	7 lbs.	77-2990	Plated Steel shaft and glass filled nylon paddles
<b>QMG-418</b>	N/A	N/A	N/A	7 lbs.	77-2990	Plated Steel shaft and glass filled nylon paddles
<b>QMG-419</b>	N/A	N/A	N/A	7 lbs.	77-2990	Plated Steel shaft and glass filled nylon paddles
<b>QMG-420</b>	N/A	N/A	N/A	8 lbs.	77-2990	Plated Steel shaft and glass filled nylon paddles
<b>QMS-430</b>	N/A	N/A	KK-5001-1	8 lbs.	SBBI-19-087	Includes QN-97 handle, HAV-500 air adj. valve and HA-57011 air hose
<b>QMS-431</b>	N/A	N/A	N/A	6 lbs.	77-2990	Stainless Steel Shaft and glass filled nylon paddles
<b>QMS-432</b>	N/A	N/A	N/A	7 lbs.	77-2990	Stainless Steel Shaft and glass filled nylon paddles
<b>QMS-433</b>	N/A	N/A	N/A	7 lbs.	77-2990	Stainless Steel Shaft and glass filled nylon paddles
<b>QMS-434</b>	N/A	N/A	N/A	8 lbs.	77-2990	Stainless Steel Shaft and glass filled nylon paddles
<b>31-129</b>	N/A	N/A	6-183	13 lbs.	77-1390	32" long shaft. Includes a 73-159 air adj. valve and an 83-1527 muffler
<b>31-396-1</b> Replaces 31-396 and 31-116	31-391-1	20:1	KK-5001-1	20 lbs.	77-2991	Includes HA-57011 13" air line, HAV-500 air adj. valve and 31-432 muffler
<b>31-425</b> Replaces 31-133	N/A	N/A	6-196	8 lbs.	77-1474	Includes 16 1/2" air line and 1/8" hex wrench
<b>843000</b>	N/A	N/A	N/A	11 lbs.	843000-EN	Includes muffler and 873409 air control valve
<b>843001</b>	N/A	N/A	N/A	11 lbs.	843001-EN	Includes muffler and 873409 air control valve

### GEAR REDUCERS / ELEVATORS

PART NUMBER	GEARBOX ASSEMBLY	GEARBOX RATIO	AIR MOTOR OR GEARBOX REPAIR KIT	SHIPPING WEIGHT	SERVICE MANUAL	MISC. NOTES
<b>31-391-1</b> Replaces 31-391	31-416	20:1	KK-5001-1	32 lbs.	77-2990, 77-2991	Includes 31-432 muffler
<b>31-393-1</b>	31-416	20:1	KK-5001-1	18 lbs.	77-2990, 77-2991	Includes 31-432 muffler
<b>41-9000</b>		N/A	6-1301	68 lbs.	77-1392	Includes air metering valve

# AGITATORS

## Equipment Selection Guide

### ACCESSORIES FOR BINKS AGITATORS / MIXERS

PRODUCT NAME AND P/N	NOTES	SHIPPING WEIGHT	SERVICE MANUAL
<b>41-661</b> 5 Gal. Steel Bucket	24 Gauge steel, painted black	4-5 lbs.	N/A
<b>73-159</b> Metering Valve – Air Control Valve	For speed adjustment of air motors	1 lb.	N/A
<b>HAV-500</b> Metering Valve – Air Control Valve	For speed adjustment of air motors	1 lb.	N/A
<b>237-578</b> Air Line Lubricator	8 oz. bowl capacity. For automatic lubrication	3 lbs.	N/A
<b>207-10858</b> Air Line Lubricator – Removable Cap	For manual lubrication of air motors with removable cap	2 lbs.	N/A
<b>84-605</b> Air Line Filter	3/8" NPT(F) port sizes.250 PSI, MWP, manual drain. 40 micron, 68 SCFM	5 lbs.	N/A
<b>41-4458</b> K Grease	.75 oz. tube Magnalube SDS # SDS-29. Used for OD of air motor shaft when assembling to air motor	1 lb.	N/A
<b>QM-142</b> Aluminum Hand Crank	For Standard Agitators w/o the air motor drive.	2 lbs.	N/A
<b>HA-57011</b> Air Hose Assy.	1/4" NPS (FBE) X 13" Long	2 lbs.	N/A
<b>207-11155-1</b> Air Motor Lubricant	2 oz. bottle of air motor lubricant	1 lb.	N/A
<b>207-11155-2</b> Air Motor Lubricant	16 oz. bottle of air motor lubricant	2 lbs.	N/A
<b>KK-5006</b> Strainer Screen and Felt kit	For 350-401 and 31-432 mufflers	1 lb.	N/A
<b>149-365, 149-693</b> Quick Mixer Blades	Stainless steel agitators/mixers only. 1 gal. / 5 gal.	4 lbs./13 lbs.	N/A

### STAINLESS STEEL BUNGHOLE ADAPTERS

PRODUCT NAME AND P/N	NOTES	SHIPPING WEIGHT	SERVICE MANUAL
<b>41-15899</b> Stainless Steel Bunghole Adapter	Bunghole Adapter for 1/2" pipe, stainless steel with nut and washer.	3 lbs.	N/A
<b>41-15898</b> Stainless Steel Bunghole Adapter	Bunghole Adapter for 3/4" pipe, stainless steel with nut and washer.	3 lbs.	N/A
<b>41-15895</b> Stainless Steel Bunghole Adapter	Bunghole Adapter for 1" pipe, stainless steel with nut and washer.	3 lbs.	N/A

### MUFFLERS

PRODUCT NAME AND P/N	NOTES	SHIPPING WEIGHT	SERVICE MANUAL
<b>41-646</b> Muffler Assembly	Used on models, 31-425, 41-3306,41-3312,41-3312-S	1 lb.	77-1474
<b>83-1527</b> Muffler Assembly	Used on models, 31-296	1 lb.	77-2055
<b>31-432</b> Muffler Assembly <b>OBSOLETE</b>	Used on models, QS-5012-1. <b>Replaced by 350-401</b>	1 lb.	77-2990
<b>350-401</b> Muffler Assembly	Used on models, QS-5012	1 lb.	77-2990

### AIR MOTORS

PRODUCT NAME AND P/N	NOTES	SHIPPING WEIGHT	SERVICE MANUAL
<b>207-12323</b> Air Motor Assembly	1.5 HP. Used with 202-55-2 and 202-55-4 Agitators	28 lbs.	77-2814
<b>31-418</b> Air Motor Assembly <b>OBSOLETE</b>	1 HP. Used with QS-5001-1, QS-5003-1, QS-5012-1 and QS-5012-1-CE Agitators. <b>Replaced by 31-418-1</b>	10 lbs.	77-2990, 77-2992
<b>37-384</b> Air Motor Assembly	1.5 HP. Used with 31-120,43-600 and 83-2476	8 lbs.	77-1617, 77-1622, 77-1833
<b>37-472</b> Air Motor Assembly	1.5 HP. Used with 31-120,43-600 and 83-2476	8 lbs.	77-1617, 77-1622, 77-1833
<b>37-478</b> Air Motor Assembly	.25 HP. Used with 41-3306, 41-3312,31-133 & 31-425	2 lbs.	77-1474
<b>37-978</b> Air Motor Assembly	1.5 HP. Used with 31-296, 83-2815 A/M	7 lbs.	77-2055
<b>83-1922</b> Air Motor Assembly	1.0 HP. Used with 41-3300 and 41-3304	5 lbs.	77-1577, 77-2055
<b>PT-410</b> Air Motor Assembly	.50 HP. Used with 83C series tanks	5 lbs.	SBBI-21-042, SBBI-21-044
<b>PT-418</b> Air Motor w/Adapter Assembly	.50 HP. Used with 83C series tanks. With adapter	6 lbs.	SBBI-21-044
<b>QMS-455</b> and <b>PT-427</b> Air Motors	.50 HP.	5 lbs.	843000, 843001, SBBI-21-068
<b>QS-4016</b> Air Motor Assembly	.50 HP. Used with QS-5001, QS-5003 and QS-5012	5 lbs.	77-2804, 77-2805, 77-2991, SBBI-19-055, SB-19-085 SB-19-087
<b>QMS-428</b> Air Motor Assembly	.50 HP. Used with QMS-430, QMS-430-CE, 183S-XXX, QMG-416	5 lbs.	843000, 843001, 77-2990, SBBI-21-068, SBBI-19-087
<b>37-260</b> Air Motor Assembly <b>OBSOLETE</b>	.50 HP. Used with 31-113, 31-114, 31-116, 31-117, 31-121, 31-131, 41-3305 and 41-3311. <b>Replaced by 31-396-1</b>	N/A	77-1657
<b>37-261</b> Air Motor Assembly <b>OBSOLETE</b>	.50 HP. Used with 31-100 - 31-112. <b>Replaced by 31-396-1</b>	N/A	77-1147, 77-1219 and 77-1220
<b>83-2815</b> Air Motor Assembly	1.0 HP. Used with 31-296 Agitator	8 lbs.	77-2055

# AGITATORS

## Equipment Selection Guide

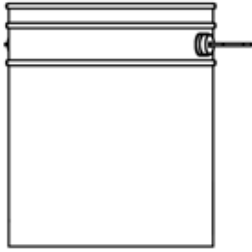

**41-661**  
5 Gallon Bucket

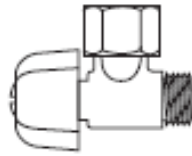

**73-159**  
Air Valve



**HAV-500**  
Air Valve



**237-578**  
Air Line Lubricator

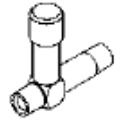

**207-10858**  
Air Line Lubricator



**207-11155-1** (2 oz.)  
**207-11155-2** (16 oz.)  
Air Line Lubricant



**84-605**  
Air Line Filter



**41-158XX Series**  
Bunghole Adapters

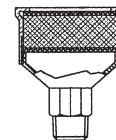

**31-432,**  
**350-401, 83-1527**  
Muffler Assemblies



**41-646**  
Muffler Assembly



**37-478**  
Air Motor

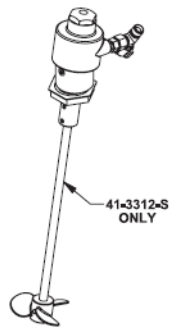

**41-3312-S**  
Stainless Steel Agitator Assembly

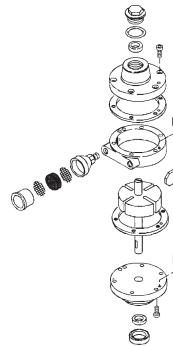

**PT-410**  
Air Motor Assembly



**149-365, 149-693**  
Quick Mixer Blades  
(see page 14)

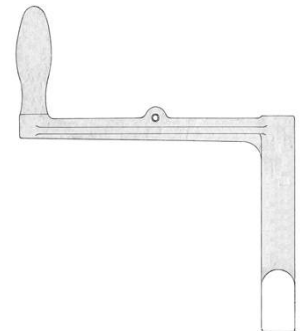

**QM-142**  
Manual Agitator Hand Crank

### OBSOLETE ITEMS

PART NUMBER (OBSOLETE)	REPLACED BY PART NUMBER	PAGE	PART NUMBER (OBSOLETE)	REPLACED BY PART NUMBER	PAGE	PART NUMBER (OBSOLETE)	REPLACED BY PART NUMBER	PAGE
41-3312-CE (OBS)	41-3312	32	QS-5001 (OBS)	QS-5001-1	32	37-260 (OBS)	31-396-1	34
31-295 (OBS)	31-296	32	QS-5003 (OBS)	QS-5003-1	32	37-261 (OBS)	31-396-1	34
31-128 (OBS)	31-129	32	QS-5012 (OBS)	QS-5012-1	34	31-418 (OBS)	31-418-1	36
31-131 (OBS)	31-397	32	149-872 (OBS)	149-873	34	31-432 (OBS)	350-401-1	36
31-114 (OBS)	31-394	32	31-116 (OBS)	31-396-1	34	31-381 (OBS)	No Replacement	—
41-3311 (OBS)	31-400	32	31-396 (OBS)	31-396-1	34	QSR-501 (OBS)	No Replacement	—
31-121 (OBS)	31-401-1	32	31-133 (OBS)	31-425	34	QSR-502 (OBS)	No Replacement	—
31-401 (OBS)	31-401-1	32	31-391 (OBS)	31-391-1	34			





## **Carlisle Fluid Technologies - Over 375 Years of Combined Finishing Expertise.**

The story of advancement in application technology is the story of Carlisle Fluid Technologies brands - DeVilbiss, Ransburg, MS, BGK and Binks. Each brand grew into its' own and became leaders in their individual product categories. Today - and collectively - those products share more than a common heritage of performance excellence and dependability. They also share a common name.

Carlisle Fluid Technologies is a unique, integrated provider of total paint system solutions. Electrostatic and conventional guns, fluid handling equipment, fluid metering, powder coating, process controls, curing - everything is designed and manufactured for system integration and to provide customers with finishing solutions adding long term value.



*SOLUTIONS FOR YOUR WORLD*

**World Class Manufacturers of:** | Process Controls | Curing & Conveying  
Electrostatics | Fluid Handling | Powder Coating | Atomization

**Carlisle Fluid Technologies US**  
16430 N. Scottsdale Road, Suite 450  
Scottsdale, AZ 85254

Tel: 1-800-992-4657  
Fax: 877-790-6965  
Email: [ghcustserv@carlisleft.com](mailto:ghcustserv@carlisleft.com)