



BINKS MACH 1 PCX HVLP SPRAY GUN (FOR PLURAL COMPONENT CATALYST INJECTION)



INTRODUCTION

The Binks MACH PLURAL COMPONENT 1PCX HVLP Gun is the lightest top quality high performance spray gun available today. You only have to pick it up to feel the difference. It's superbly balanced forged aluminum body offers the operator extra comfort and control. All of the gun's components are machined and finished to exacting tolerances and only the best materials are used, ensuring years of peak efficiency.

The MACH 1PCX HVLP Gun is a conventional style air spray gun with special nozzles and modifications that allow it to operate at high transfer efficiencies in compliance with the "California South Coast Air Quality Management District" regulations as a "High Volume, Low Pressure air spray gun.

A specially designed catalyst injector device is integrated to the HVLP Gun to inject Methyl Ethyl Ketone Peroxide or other catalyst into the stream of coating material. The catalyst is injected immediately after the coating exits the fluid nozzle for even distribution across the pattern.

The air inlet passage in the gun body incorporates a venturi which limits airflow. High pressure airflow is converted to low pressure at this point. Special air and fluid nozzles enable the gun to atomize fluid at low air pressures and velocities, creating the "soft spray" effect for high transfer efficiencies.

To obtain optimum performance from your new MACH 1PCX HVLP Spray Gun, read all instructions carefully.

1. Lightweight Air Nozzle
2. Fluid Inlet 3/8 NPS(m)
- 2A. Catalyst Inlet 1/4 NPS(m)
3. Extra Smooth Trigger Action
4. Stainless Steel Nozzle and Needle
5. Side Port Control
6. Fluid Control
7. Forged Aluminum Body
8. Air Inlet 1/4 NPS(m)
9. Catalyst Valve Assembly 316 SS

In this part sheet, the words **WARNING**, **CAUTION** and **NOTE** are used to emphasize important safety information as follows:

WARNING

Hazards or unsafe practices which could result in severe personal injury, death or substantial property damage.

CAUTION

Hazards or unsafe practices which could result in minor personal injury, product or property damage.

NOTE

Important installation, operation or maintenance information.

WARNING

Read the following warnings before using this equipment.



READ THE MANUAL

Before operating finishing equipment, read and understand all safety, operation and maintenance information provided in the operation manual.



OPERATOR TRAINING

All personnel must be trained before operating finishing equipment.



EQUIPMENT MISUSE HAZARD

Equipment misuse can cause the equipment to rupture, malfunction, or start unexpectedly and result in serious injury.



LOCK OUT / TAG-OUT

Failure to de-energize, disconnect, lock out and tag-out all power sources before performing equipment maintenance could cause serious injury or death.



AUTOMATIC EQUIPMENT

Automatic equipment may start suddenly without warning.



PRESSURE RELIEF PROCEDURE

Always follow the pressure relief procedure in the equipment instruction manual.



KEEP EQUIPMENT GUARDS IN PLACE

Do not operate the equipment if the safety devices have been removed.



KNOW WHERE AND HOW TO SHUT OFF THE EQUIPMENT IN CASE OF AN EMERGENCY



WEAR SAFETY GLASSES

Failure to wear safety glasses with side shields could result in serious eye injury or blindness.



INSPECT THE EQUIPMENT DAILY

Inspect the equipment for worn or broken parts on a daily basis. Do not operate the equipment if you are uncertain about its condition.



NEVER MODIFY THE EQUIPMENT

Do not modify the equipment unless the manufacturer provides written approval.



NOISE HAZARD

You may be injured by loud noise. Hearing protection may be required when using this equipment.



PROJECTILE HAZARD

You may be injured by venting liquids or gases that are released under pressure, or flying debris.



PINCH POINT HAZARD

Moving parts can crush and cut. Pinch points are basically any areas where there are moving parts.



STATIC CHARGE

Fluid may develop a static charge that must be dissipated through proper grounding of the equipment, objects to be sprayed and all other electrically conductive objects in the dispensing area. Improper grounding or sparks can cause a hazardous condition and result in fire, explosion or electric shock and other serious injury.



WEAR RESPIRATOR

Toxic fumes can cause serious injury or death if inhaled. Wear a respirator as recommended by the fluid and solvent manufacturer's Safety Data Sheet.



TOXIC FLUID & FUMES

Hazardous fluid or toxic fumes can cause serious injury or death if splashed in the eyes or on the skin, inhaled, injected or swallowed. LEARN and KNOW the specific hazards or the fluids you are using.



FIRE AND EXPLOSION HAZARD

Improper equipment grounding, poor ventilation, open flame or sparks can cause a hazardous condition and result in fire or explosion and serious injury.



MEDICAL ALERT

Any injury caused by high pressure liquid can be serious. If you are injured or even suspect an injury:

- Go to an emergency room immediately.
- Tell the doctor you suspect an injection injury.
- Show the doctor this medical information or the medical alert card provided with your airless spray equipment.
- Tell the doctor what kind of fluid you were spraying or dispensing.



GET IMMEDIATE MEDICAL ATTENTION

To prevent contact with the fluid, please note the following:

- Never point the gun/valve at anyone or any part of the body.
- Never put hand or fingers over the spray tip.
- Never attempt to stop or deflect fluid leaks with your hand, body, glove or rag.
- Always have the tip guard on the spray gun before spraying.
- Always ensure that the gun trigger safety operates before spraying.

IT IS THE RESPONSIBILITY OF THE EMPLOYER TO PROVIDE THIS INFORMATION TO THE OPERATOR OF THE EQUIPMENT. FOR FURTHER SAFETY INFORMATION REGARDING THIS EQUIPMENT, SEE THE GENERAL EQUIPMENT SAFETY BOOKLET (77-5300).

Binks MACH 1 PCX HVLP SPRAY GUN

OPERATION AND MAINTENANCE INSTRUCTIONS FOR THE MACH 1PCX HVLP SPRAY GUN

Your new MACH 1PCX HVLP Spray Gun is exceptionally rugged in construction and is built to stand up under hard, continuous use. However, like any other fine precision instrument, its most efficient operation depends on a knowledge of its construction, operation and maintenance. Properly handled and cared for, it will produce uniform finishing and mixing results long after other spray guns have worn out.

IMPORTANT: Before removing any components from the spray gun, shut off the air and material pressure, and bleed off excess material.

BINKS OIL AND WATER EXTRACTOR IS IMPORTANT

Achieving a fine spray finish without the use of a good oil and water extractor is virtually impossible.

A Binks Regulator/Extractor serves a double purpose. It eliminates blistering and spotting by keeping air free of oil and water, and it gives precise air pressure control at the gun. An extractor with a minimum 1/2" pipe inlet is recommended.

SET-UP FOR SPRAYING

CONNECTING GUN TO THE AIR HOSE

Air should be supplied by 5/16" air hose (71-1203) typical, with a 1/4" NPS(f) connection at the gun end. Hose lengths in excess of 50 ft., use 3/8" hose (71-1356) typical.

CONNECTING THE GUN TO THE MATERIAL HOSE

Fluid should be supplied by 3/8" fluid hose with 3/8" NPS(f) connection at the gun end. A 1/4" hose is recommended for use with low viscosity materials. Fluid hoses of different composition are available for special fluids.

CONNECTING THE GUN TO THE CATALYST HOSE

The catalyst should be supplied by 1/8" catalyst hose (102-3027) typical, with a 316 SS 1/4"NPS(f) connections at both ends.

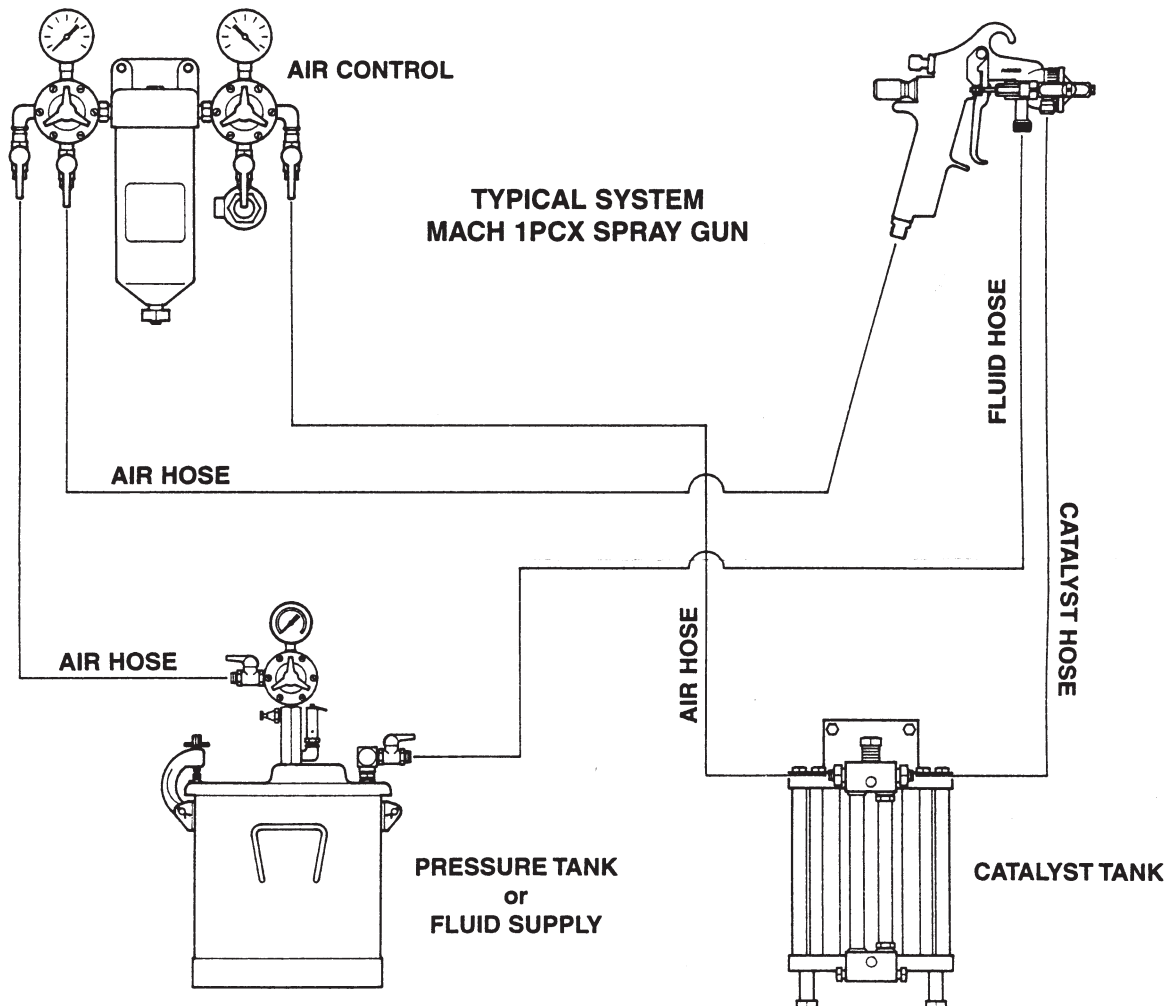

Binks MACH 1 PCX HVLP SPRAY GUN

OPERATING THE MACH 1PCX HVLP SPRAY GUN

CONTROLLING THE FAN SPRAY

The fan pattern is controlled by means of a side port control. Turning this control clockwise until it is closed will give a round spray, turning it counter-clockwise will widen the spray into a fan shape. The air cap cannot be rotated (See drawing below).

CONTROLLING THE MATERIAL FLOW

When used with a pressure tank, an increase in air pressure will increase the rate of flow. The correct fluid nozzle size should be selected for the correct material flow rate. It is not recommended to use the fluid control knob (item 13), to control resin flow because the catalyst flow will remain constant, causing over catalyzation of the resin.

NOTE: Feathering and changing the needle valve opening will affect the ratio of catalyst: resin and gel.

NOZZLE TYPES

Spray patterns are determined by nozzle selection and vary somewhat depending on size, angle, nozzle orifice and output.

TROUBLESHOOTING

FAULTY SPRAY

Faulty spray is often caused by:

1. Foreign material in the air and/or fluid passages.
2. Viscosity too high for spraying, air supply or pressure inadequate.
3. Worn or damaged nozzle surfaces.
4. Gellation in gun head air passages.
5. Loose fluid nozzle.
6. Insufficient material available, check supply and replenish if necessary.

NOTE: Care must be exercised when cleaning with metal instruments. These parts are carefully machined and any damage to them will cause faulty spray patterns. If either the air nozzle or fluid nozzle are damaged, these parts must be replaced before perfect spray patterns can be obtained.

AIR LEAKS

1. Leaky Spindle (9). Inspect, clean or replace.
2. O-Rings (6) missing or damaged. Inspect and replace.
3. Damaged seat surface in gun body. Replace.

UNMIXED RESIN

1. Clogged filter. Remove the manifold and clean debris from the filter screen.
2. Plugged manifold. Use 102-2658 manifold cleaner to unplug.
3. Insufficient catalyst pressure. Increase pressure.
4. Loose catalyst needle nuts. Readjust, tighten.

OVER CATALYZATION

1. Material Knob (13) has been closed to reduce the flow of resin. Readjust.
2. Fluid Nozzle (2) is partially clogged and is restricting the resin flow. Clean.

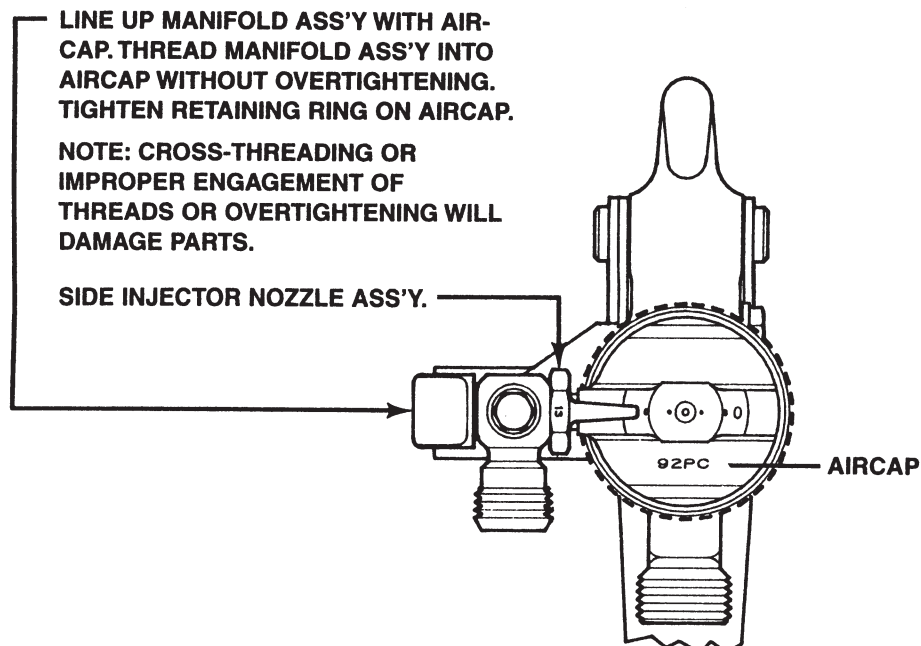

Binks MACH 1 PCX HVLP SPRAY GUN

MAINTENANCE

TO REPLACE SPINDLE ASSEMBLY (Air Valve)

Remove the Fluid Control Knob (13), Spring (10) and Needle Assembly (12). Using an Allen Head Wrench, loosen the Housing (11) until it is finger tight. Reinsert Needle (12) and finish unscrewing Housing (11). Remove Items 6 thru 12 as one piece. Replace Spindle Ass'y (9) and reinsert items 6 thru 12, as one piece, back into gun and hand-tighten Housing (11). Next, remove Needle (12) and tighten Housing (11) with Allen Head Wrench. Reinsert Needle (12), Spring (10) and Fluid Control Knob (13).

NOTE: Springs must be replaced in the same order as they were removed from gun.

NOTE: If the instructions are not followed as described, Items 12 and 13 may drop into air passages.

TO REPLACE NEEDLE SEAL AND GLAND ADAPTER IN FLUID INLET

Remove Fluid Control Knob (13) and Spring (10) and pull out Needle Ass'y (12). Unscrew Packing Nut (25) and remove Spring (24) and Seal Backup (23). Using a No.10 X 1 1/4" coarse thread wood screw (Binks Part No. 20-6536) or a small sheet metal screw, remove the Needle Seal (22) and Gland Adapter (21). Replace Gland Adapter (21) and Needle Seal (22). Reinsert Seal Backup (23), Spring (24) and screw on Packing Nut (25) a couple of turns so it fits loosely by hand. Reassemble Needle (12), Spring (10) and Material Valve Control Knob (13). Finally, tighten Packing Nut (25) until it bottoms out on Fluid Inlet (18).

ADJUSTMENT OF MATERIAL AND CATALYST NEEDLE

The needle assembly is adjustable for lengths by means of the needle, needle cap and needle locknut. These should be adjusted so that when the trigger assembly is in contact with the spindle assembly, a movement of the spindle assembly of 1/16" minimum is required before the material needle moves. Under no circumstances should the material valve open before the air valve or catalyst valve assembly.

The correct timing adjustment is: air catalyst-resin. The timing is correctly set at the factory. However, repositioning the catalyst needle nuts will affect the timing.

GUN CLEANING

Submerging in solvents is a poor practice because of the solvent residue that may cling to interior air passages. Clean solvent *must* be used if the gun is to be submerged.

The best practice is to remove the air nozzle and to flush solvent through the fluid passages. All nozzles may be placed in solvent for washing. The nozzle orifice and angle passageways are critical. Always wash and rinse with a clean solvent to prevent residue accumulation in the minute holes. If using metal instruments for cleaning, use extreme caution. **DO NOT** gouge or distort surfaces. Use the brush supplied with the gun.

NOTE: Some air quality agencies prohibit the spraying of solvent into the atmosphere when flushing spray guns. In some areas spray guns must be cleaned in a completely enclosed gun cleaning device which prevents solvent vapors from escaping to the atmosphere. Consult with your local Binks distributor or contact the closest Binks branch if you are not sure of requirements in your area.

OPTIONS

INJECTOR ASS'Y

102-2851

102-2852

INJECTOR I.D.

.013

.016

IDENTIFICATION

13

16

Binks MACH 1 PCX HVLP SPRAY GUN

GENERAL SPRAY INSTRUCTIONS

To reduce overspray and obtain maximum efficiency, always spray with the lowest possible fluid/air pressure. This will produce an acceptable spray pattern.

Excessive atomizing air pressures can increase overspray, reduce transfer efficiency, and with some materials, atomizing air pressures should not exceed 10 PSI. See the table in the air pressure recommendation and regulatory note on page 8.

For best results, use only enough pressure for desired flow (1.5-2 pounds.). Higher fluid pressure may be required for heavy bodied materials, low fluid pressures will produce a narrower than normal spray pattern.

SPRAY TECHNIQUE

The first requirement for a good resultant finish is the proper handling of the gun. The gun should be held perpendicular to the surface being covered and moved parallel with it.

The distance between the gun and surface should be 12 to 14 inches, depending on material and atomizing pressure. The material deposited should always be even and wet. Lap each stroke over the preceeding stroke to obtain a uniform finish.

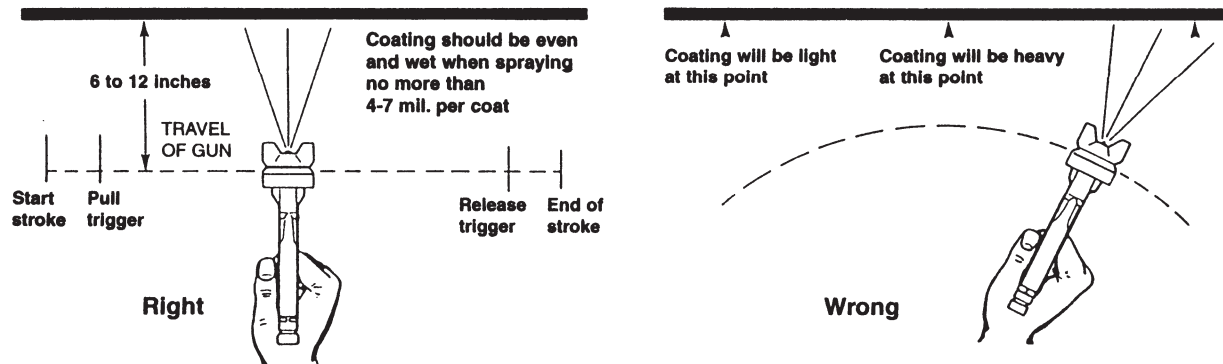

Binks MACH 1 PCX HVLP SPRAY GUN

FLUID NOZZLE DESCRIPTION	FLUID NOZZLE PART NO.	FLUID NOZZLE ORIFICE SIZE	COMPATIBLE AIR CAPS DESCRIPTION AND PART NO.	COMPATIBLE NEEDLE PART NO.
90	45-9000	(.030 DIA.) 0.6mm	91PC, 102-2682 & 92PC, 102-2681	54-3941
90F	45-9002	(.030 DIA.) 0.6mm	91PC, 102-2682 & 92PC, 102-2681	54-4022
91	45-9100	(.040 DIA.) 1.0mm	91PC, 102-2682 & 92PC, 102-2681	54-3941
91F	45-9102	(.040 DIA.) 1.0mm	91PC, 102-2682 & 92PC, 102-2681	54-4023
92	45-9200	(.046 DIA.) 1.2mm	92PC, 102-2681	54-3941
92F	45-9202	(.046 DIA.) 1.2mm	92PC, 102-2681	54-4024
94F	45-9402	(.055 DIA.) 1.4mm	92PC, 102-2681	54-4026
905	45-9050	(.089 DIA.) 2.3mm	905PC, 102-2684	54-3941

AIR PRESSURE REQUIREMENTS W/92PC AIR NOZZLE

Atomizing PSI	Side Port Control		Nozzle Atomizing Air Flow (SCFM)
	Gun Inlet PSI	Regulator PSI*	
03	06.0	08.0	4.5
05	08.5	10.0	6.0
09	13.5	17.5	7.5
10	15.0	19.0	8.0

NOTE: Regulator pressures are based on 25' of 5/16" hose in good condition without Quick-Disconnects or other restrictive fittings. Use the Air Nozzle Test Gauge accessory to confirm the atomizing/regulator pressure relationship for your actual air supply set-up. Adjust air pressure as necessary for your specific application. Maximum recommended atomizing air pressure is 10 PSI.

Binks MACH 1 PCX HVLP SPRAY GUN

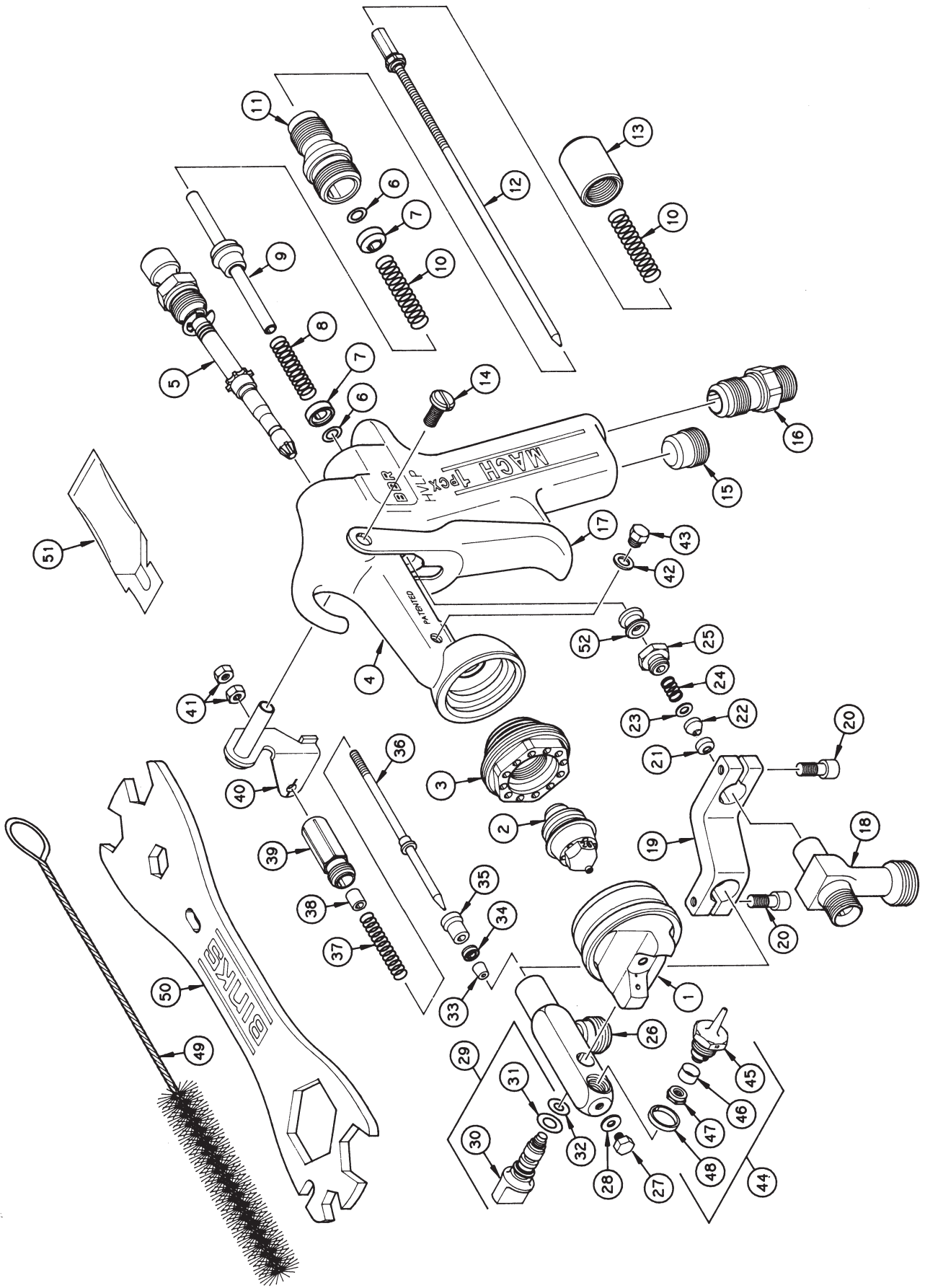

Binks MACH 1 PCX HVLP SPRAY GUN

PARTS LIST

(When ordering, please specify PART NO.)

ITEM NO.	PART NO.	DESCRIPTION	QTY.	ITEM NO.	PART NO.	DESCRIPTION	QTY.
1	*	AIR CAP ASSEMBLY	1	31	20-6525 ■	O-RING	1
2	*	FLUID NOZZLE	1	32	20-6524 ■	O-RING	1
3	54-3543	HEAD INSERT	1	33	102-2715	CATALYST SEAT	1
4	54-3922	MACH 1 GUN BODY	1	34	102-647	"U" CUP SEAL	1
5	54-3946	SIDE PORT CONTROL ASS'Y	1	35	102-2716	FRONT BUSHING	1
6	20-4615	O-RING	2	36	102-2722	NEEDLE ASSEMBLY	1
7	54-3515	HOUSING	2	37	102-2717	SPRING	1
8	54-3520	SPRING, Yellow	1	38	102-2718	REAR BUSHING	1
9	54-3512	SPINDLE ASSEMBLY	1	39	102-2719	SPRING HOUSING	1
10	54-3518	SPRING, Blue	1	40	102-483	LEVER ASSEMBLY	1
11	54-3541	HOUSING	1	41	102-2728	NUT	2
12	*	HVLP NEEDLE ASS'Y	1	42	54-3925	GASKET	1
13	54-3606	FLUID CONTROL KNOB	1	43	54-3928	PLUG, 10-32 X 3/16 Hex Hd. .	1
14	82-126	TRIGGER SCREW	1	44	▲	INJECTOR ASSEMBLY	1
15	54-3504	PLUG	1	45	▲	INJECTOR (part of item 44)....	1
16	54-768	AIR CONNECTION	1	46	102-2729 ■	FILTER (part of item 44)	1
17	54-3547	TRIGGER	1	47	102-2876	FILTER RETAINER (part of item 44)	1
18	54-3533	FLUID INLET	1	48	102-2871 ■	SEAL (part of item 44)	1
19	102-2709	"S" BRACKET	1	49	82-469	GUN BRUSH	1
20	20-2652	SCREW, 8-32 X 3/8" Soc. Hd.	2	50	54-3918	WRENCH	1
21	54-4264 ●	GLAND ADAPTER	1	51	54-3871	GUNNERS MATE	1
22	54-4265 ●	NEEDLE SEAL	1	52	54-3513	VALVE SPINDLE CAP	1
23	54-4266 ●	SEAL BACKUP	1	53	102-2658 ■	MANIFOLD CLEANER (Not shown)	1
24	54-4267 ●	SPRING	1	54	102-2656 ■	LARGE O-RING TOOL (Not shown)	1
25	54-4263 ●	PACKING NUT	1	55	102-2657 ■	SMALL O-RING TOOL (Not shown)	1
26	102-2874	BODY WELDMENT	1				
27	102-2713	PLUG	1				
28	102-2708	GASKET	1				
29	102-2872	FLUID MANIFOLD PLUG ASS'Y	1				
30	102-2873	FLUID MANIFOLD PLUG	1				

* See Air and Fluid Nozzle Chart on pg. 5.

● Part of Self-Adjusting Packing Kit (54-4261) without needle.

▲ See Injector Chart under Options on pg. 4.

■ Part of Spare Parts Kit (102-2720).

Binks MACH 1 PCX HVLP SPRAY GUN

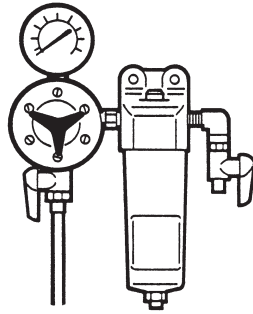

Binks oil and water extractor is important

Achieving a fine spray finish without the use of a good oil and water extractor is virtually impossible.

A Binks Regulator/Extractor serves a double purpose. It eliminates blistering and spotting by keeping air free of oil and water and it gives precise air pressure control at the gun.

Atomizing pressure must be set to allow for the drop in air pressure between the regulator and the spray gun.

With 60 psi applied at air supply:

Approx. 5 1/2 PSI at nozzle

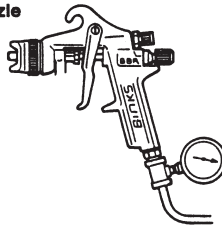

Only 34 psi at gun inlet

25 feet of 1/4" I.D. hose causes a drop of 26 psi between the air supply and the gun.

(NOT RECOMMENDED)

Approx. 9 PSI at nozzle

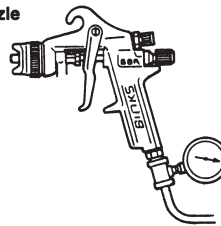

48 psi at gun inlet

25 feet of 5/16" I.D. hose causes a drop of 12 psi between the air supply and the gun. For this reason we recommend the use of 5/16" hose.

(RECOMMENDED)



1/4"

Cross section view showing comparison of inside hose diameters (actual size).

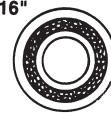

5/16"

IMPORTANT REGULATORY NOTE

Some Regulatory Agencies prohibit the operation of HVLP spray guns above 10 psi nozzle atomizing pressure. Users subject to this type of regulation should not exceed the gun inlet pressure indicated on the aircap and/or in these instructions. See Air Pressure Recommendations, Page 5 and General Spray Instructions, Page 5. It is recommended that the Nozzle Test Gauge (see below) be used to confirm actual nozzle operating pressure.

It may also be a requirement of some Regulatory Agencies that users have this Air Nozzle Test Gauge Assembly available on site to verify that the gun is being operated within the limits of applicable rules.

AIR NOZZLE TEST GAUGE ASSEMBLY

54-3935 for 90 Series Nozzles
54-3908 for 900 Series Nozzles

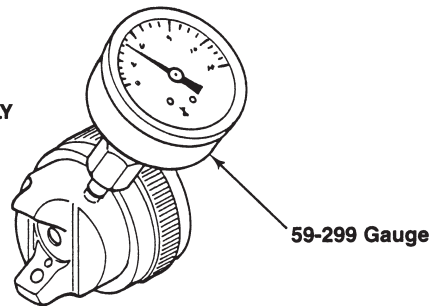

NOTES

WARRANTY POLICY

This product is covered by Carlisle Fluid Technologies' materials and workmanship limited warranty. The use of any parts or accessories, from a source other than Carlisle Fluid Technologies, will void all warranties. Failure to reasonably follow any maintenance guidance provided may invalidate any warranty.

For specific warranty information please contact Carlisle Fluid Technologies.

For technical assistance or to locate an authorized distributor, contact one of our international sales and customer support locations.

Region	Industrial / Automotive	Automotive Refinishing
Americas	Tel: 1-800-992-4657 Fax: 1-888-246-5732	Tel: 1-800-445-3988 Fax: 1-800-445-6643
Europe, Africa, Middle East, India	Tel: +44 (0)1202 571 111 Fax: +44 (0)1202 573 488	
China	Tel: +8621-3373 0108 Fax: +8621-3373 0308	
Japan	Tel: +81 45 785 6421 Fax: +81 45 785 6517	
Australia	Tel: +61 (0) 2 8525 7555 Fax: +61 (0) 2 8525 7575	

For the latest information about our products, visit www.carlisleleft.com

Carlisle Fluid Technologies is a global leader in innovative finishing technologies. Carlisle Fluid Technologies reserves the right to modify equipment specifications without prior notice.

BGK™, Binks®, DeVilbiss®, Hosco®, MS®, and Ransburg® are all registered trademarks of Carlisle Fluid Technologies, Inc.

©2020 Carlisle Fluid Technologies, Inc.
All rights reserved.

