

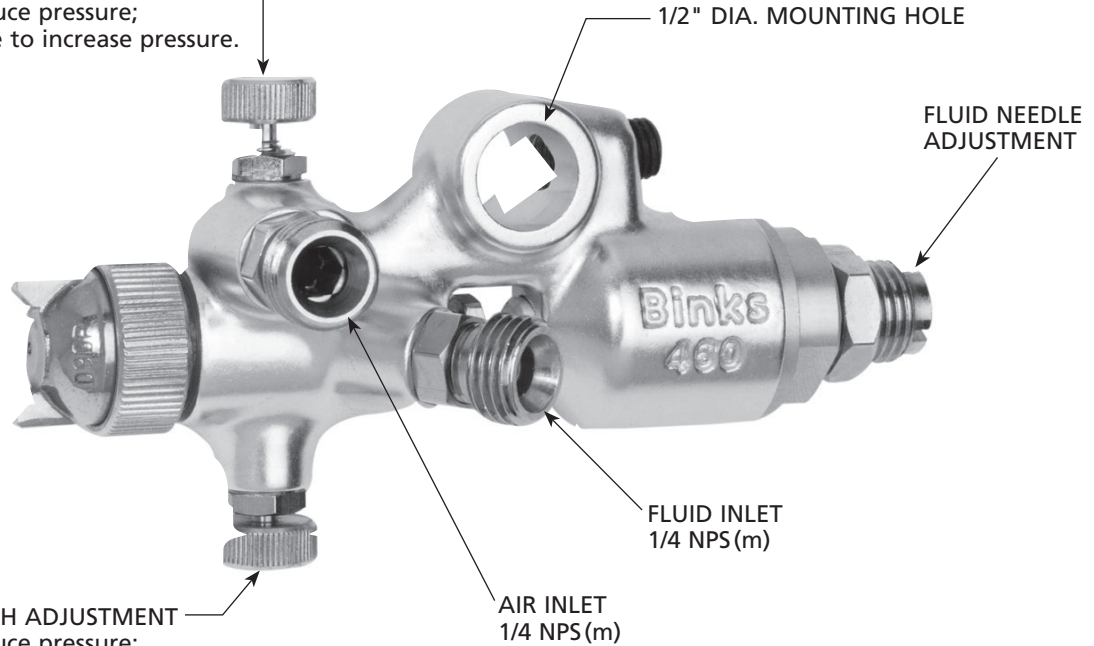

Binks Model 460 LIGHTWEIGHT AUTOMATIC SPRAY GUN

AIR FLOW ADJUSTMENT
Clockwise to reduce pressure;
Counterclockwise to increase pressure.



DESCRIPTION

The Binks 460 Automatic Spray Gun is a small precision gun designed with accuracy in mind, for ease of fitting to existing automatic and semi-automatic machine. Its compact dimensions also enable the gun to be installed neatly and at close quarters, where the standard range of automatics cannot be accommodated.

FEATURES

- Aluminum alloy body with brass air nozzle.
- Stainless steel needle valve and springs.
- Both gun operation and spray variation is controlled from a single air supply.
- Control valves for atomization fan and air flow.
- No lag, instant piston controlled "on and off".
- A range of fluid nozzles for applying many liquid coatings.

CA PROP
65

PROP 65 WARNING
WARNING: This product contains chemicals known to the State of California to cause cancer and birth defects or other reproductive harm.

GUN ASSEMBLY ORDERING INFORMATION

6401-1800-5

460 Gun J920SS-J92P with .020" Fluid Nozzle

6401-1900-5

460 Gun J930SS-J92P with .030" Fluid Nozzle

6401-2000-5

460 Gun J940SS-J92P with .040" Fluid Nozzle

6401-2100-8

460 Gun K960SS-K92P with .060" Fluid Nozzle

SPECIFICATIONS:

Max Air Pressure: 100 PSI/6.8 Bar

Min Air Pressure: 50PSI/3.4 Bar

Max Fluid Pressure: 100 PSI/6.8 Bar

Air Volume Requirements: 20 SCFM Max

Gun Body: Aluminum Forging

Fluid Path: Stainless Steel

Fluid Inlet: 1/4" NPS (M)

Air Inlet: 1/4" NPS (M)

Gun Weight: .43 Ibs/.2kg

Gun Mounting Hole: 1/2" Dia.

Replaces
Part Sheet
77-2019R-3

Part
Sheet
77-2019R-4

In this part sheet, the words **WARNING**, **CAUTION** and **NOTE** are used to emphasize important safety information as follows:

⚠ WARNING
 Hazards or unsafe practices which could result in severe personal injury, death or substantial property damage.

⚠ CAUTION
 Hazards or unsafe practices which could result in minor personal injury, product or property damage.

NOTE
 Important installation, operation or maintenance information.

⚠ WARNING

Read the following warnings before using this equipment.



READ THE MANUAL
 Before operating finishing equipment, read and understand all safety, operation and maintenance information provided in the operation manual.



WEAR SAFETY GLASSES
 Failure to wear safety glasses with side shields could result in serious eye injury or blindness.



DE-ENERGIZE, DEPRESSURIZE, DISCONNECT AND LOCK OUT ALL POWER SOURCES DURING MAINTENANCE
 Failure to De-energize, disconnect and lock out all power supplies before performing equipment maintenance could cause serious injury or death.



OPERATOR TRAINING
 All personnel must be trained before operating finishing equipment.



EQUIPMENT MISUSE HAZARD
 Equipment misuse can cause the equipment to rupture, malfunction, or start unexpectedly and result in serious injury.

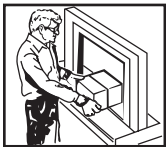

KEEP EQUIPMENT GUARDS IN PLACE
 Do not operate the equipment if the safety devices have been removed.

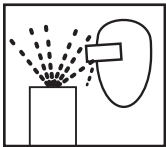

PROJECTILE HAZARD
 You may be injured by venting liquids or gases that are released under pressure, or flying debris.



PINCH POINT HAZARD
 Moving parts can crush and cut. Pinch points are basically any areas where there are moving parts.



AUTOMATIC EQUIPMENT
 Automatic equipment may start suddenly without warning.



INSPECT THE EQUIPMENT DAILY
 Inspect the equipment for worn or broken parts on a daily basis. Do not operate the equipment if you are uncertain about its condition.



NEVER MODIFY THE EQUIPMENT
 Do not modify the equipment unless the manufacturer provides written approval.



KNOW WHERE AND HOW TO SHUT OFF THE EQUIPMENT IN CASE OF AN EMERGENCY



PRESSURE RELIEF PROCEDURE
 Always follow the pressure relief procedure in the equipment instruction manual.



NOISE HAZARD
 You may be injured by loud noise. Hearing protection may be required when using this equipment.



STATIC CHARGE
 Fluid may develop a static charge that must be dissipated through proper grounding of the equipment, objects to be sprayed and all other electrically conductive objects in the dispensing area. Improper grounding or sparks can cause a hazardous condition and result in fire, explosion or electric shock and other serious injury.



FIRE AND EXPLOSION HAZARD
 Never use 1,1,1-trichloroethane, methylene chloride, other halogenated hydrocarbon solvents or fluids containing such solvents in equipment with aluminum wetted parts. Such use could result in a serious chemical reaction, with the possibility of explosion. Consult your fluid suppliers to ensure that the fluids being used are compatible with aluminum parts.



TOXIC FLUID & FUMES
 Hazardous fluid or toxic fumes can cause serious injury or death if splashed in the eyes or on the skin, inhaled, injected or swallowed. LEARN and KNOW the specific hazards of the fluids you are using.



WEAR RESPIRATOR
 Toxic fumes can cause serious injury or death if inhaled. Wear a respirator as recommended by the fluid and solvent manufacturer's Material Safety Data Sheet.

FOR FURTHER SAFETY INFORMATION REGARDING BINKS AND DEVILBISS EQUIPMENT, SEE THE GENERAL EQUIPMENT SAFETY BOOKLET (77-5300).

Binks MODEL 460 LIGHTWEIGHT AUTOMATIC SPRAY GUN

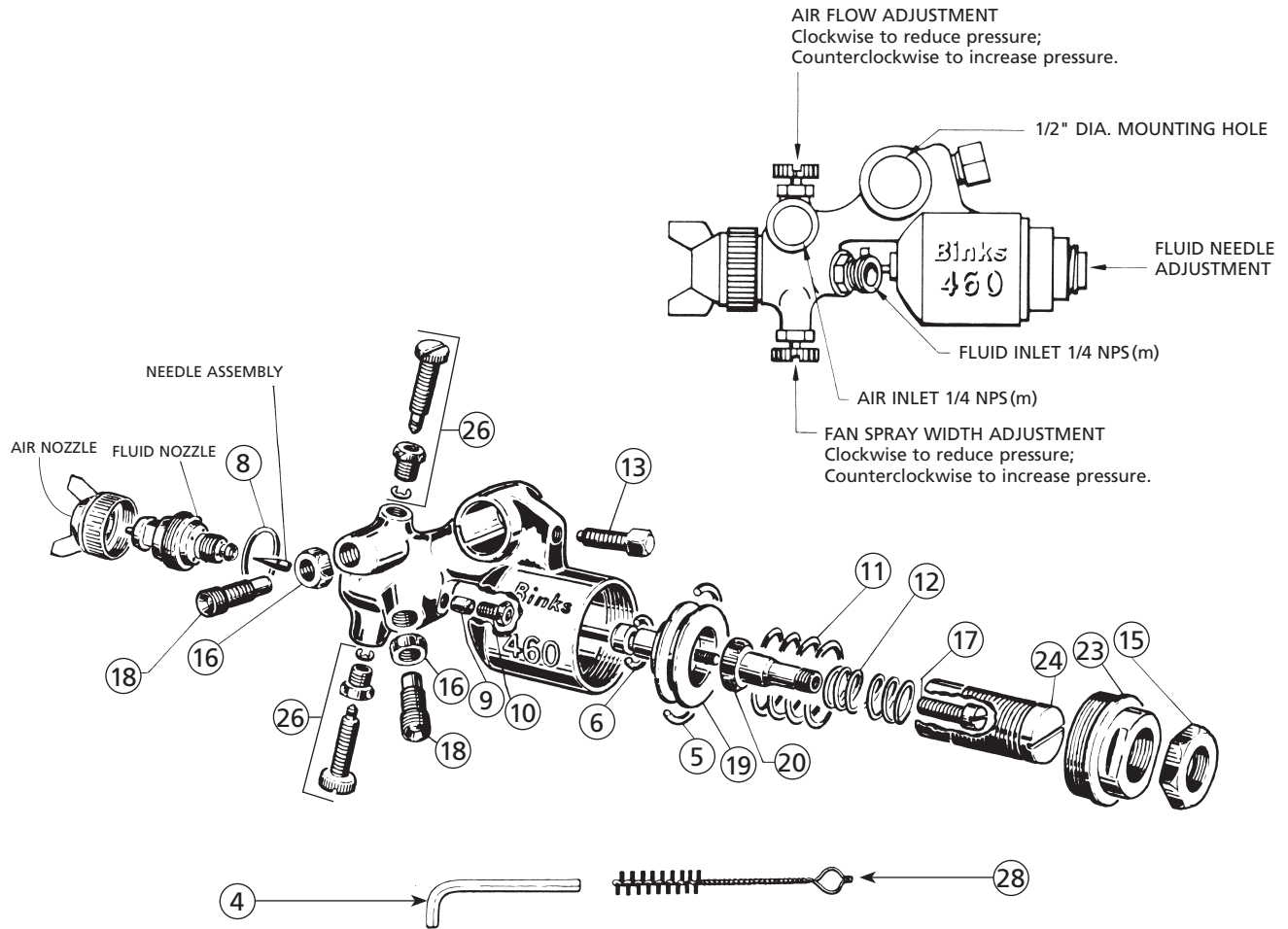

PARTS LIST

When ordering, please specify Part No.

ITEM NO.	PART NO.	DESCRIPTION	QTY.	ITEM NO.	PART NO.	DESCRIPTION	QTY.
1	—	AIR NOZZLE	1	13	—	5/16" - 24 CUP POINT SET SCREW 1/2" LONG	1
2	—	FLUID NOZZLE	1	15	54-2868	LOCKNUT	1
3	—	NEEDLE ASSEMBLY	1	16	54-2869	LOCKNUT	2
4	—	WRENCH, 7/32 HEX.....	1	17	54-2870	SCREW	1
5	20-2111 •	O-RING	1	18	54-2871	CONNECTOR.....	2
6	20-3236 •	O-RING.....	1	19	54-2872	PISTON.....	1
8	54-2209 •	GASKET.....	1	20	54-2873	SPIGOT.....	1
9	54-2292 •	PACKING.....	1	23	54-2876	COVER.....	1
10	54-2294 •	SCREW.....	1	24	54-2877	SCREW.....	1
11	54-2860 •	SPRING.....	1	26	54-2879	SIDE PORT CONTROL	2
12	54-2861 •	SPRING.....	1	28	OMX-88	GUN BRUSH.....	1

• 6-1302 Repair Kit (kit includes Items 5, 6, 8, 9, 10, 11 & 12)

INSTALLATION, OPERATION & MAINTENANCE

GUN MOUNTING

A hexagon screw (13) will secure the spray gun to the 54-380 gun mounting rod. For special mountings, a 1/2" dia. rod will fit the hole in the top of the gun body.

HOSE LENGTH

Install minimum hose length from valve to gun to minimize time required for "off-on" response of gun.

CONNECTIONS

The air connection and fluid connection are both 1/4 NPS. The air connection is stamped "a".

AIR SUPPLY

Since the gun has its own control, atomizing air may be taken directly from the main line. However, if regulated air is used, 50 PSI minimum is required to actuate gun fluid valve piston. When rapid "off-on" operation is required, use a 3-way valve which exhausts to atmosphere, in place of a 2-way valve.

SPRAY PATTERN

The width of spray pattern is controlled by the control assembly (26). Vertical or horizontal position of the spray is obtained by rotating the air nozzle.

ATOMIZATION

Air volume to the nozzle is controlled by the control assembly (26) located adjacent to the air inlet connection.

FLUID CONTROL

The rate of fluid flow is controlled by a combination of the selection of the correct nozzle orifice size and adjustment of fluid pressure. The maximum fluid flow rate is approximately 8 fluid ounces per minute. Fine adjustment of the fluid flow can be obtained by controlling the travel of the needle valve. Clockwise rotation of the screw (24) decreases the needle travel and counterclockwise rotation increases the travel. The locknut (15) is used to lock the screw (24) after adjustment.

FAULTY SPRAY

Caused by improper cleaning, or dried fluid on nozzle tip or in the air nozzle. Soak these parts in solvent to soften the dried fluid and remove with a brush or cloth.

⚠ CAUTION

Never use metal instruments to clean air or fluid nozzles. These parts are carefully machined and any damage to them will cause a faulty spray.

If either air nozzle or fluid nozzle is damaged, the part must be replaced before a perfect spray can be obtained.

SPITTING

To eliminate spitting and dripping, turn on atomizing air before turning on fluid.

NEEDLE ADJUSTMENT

The correct setting is to allow approximately 1/16" piston travel before contacting NEEDLE. Adjustment is made by loosening the screw (17) on rear of needle and rotating the spring guide (20) either forward to reduce or back to increase clearance.

AIR LEAKAGE INTO AIR CYLINDER VENT

Remove piston (19) and inspect for dirt or damage to large o-ring (5). Clean piston and cylinder. Replace o-ring if necessary. Lubricate with white petroleum jelly.

AIR LEAKAGE AT FLUID NEEDLE

Remove piston (19) and inspect for dirt or damage to small o-ring (6). Replace if necessary.

FLUID LEAKAGE AT PACKING GLAND

Tighten screw (10) and slightly "back-off" screw to set packing. If leakage continues, replace packing.

CLEANING THE GUN

Under no circumstances should the complete gun be immersed in thinners or solvents.

Binks MODEL 460 GUN FLUID NOZZLE, NEEDLE & AIR CAP SELECTION CHART

Fluid Nozzle	Orifice Size	Fluid Needle	Air Nozzle	Approx. Air Consumption SCFM with Specific Dynamic Air Pressure (PSI) at air cap			Type of Spray Pattern	*Max. Spray Pattern Size @ 5" Distance
				30 PSI	50 PSI	70 PSI		
J920SS (PN 45-84)	.020" (.5 mm)	940 (PN 47-454)	J92P (PN 46-131)	6.4	8.5	10.5	ELLIPSE / STRAIGHT SIDES	6"
J930SS (PN 45-85)	.030" (.75 mm)	940 (PN 47-454)	J92P (PN 46-131)	6.4	8.5	10.5	ELLIPSE / STRAIGHT SIDES	7.5"
J940SS (PN 45-86)	.040" (1.0 mm)	940 (PN 47-454)	J92P (PN 46-131)	6.4	8.5	10.5	ELLIPSE / STRAIGHT SIDES	8"
J940SS (PN 45-86)	.040" (1.0 mm)	940 (PN 47-454)	J92R (PN 46-126)	4	6	8	ROUND	2"
K960SS (PN 45-87)	.060" (1.5 mm)	960 (PN 47-455)	K92P (PN 46-134)	7.2	10.6	14	ELLIPSE / STRAIGHT SIDES	9.5"

*Spray pattern for reference only. Pattern size will vary slightly with flow and viscosity of the materials.

WARRANTY

This product is covered by Binks' 1 Year Limited Warranty.

Binks Sales and Service: www.binks.com



U.S.A./Canada Customer Service
195 Internationale Blvd.
Glendale Heights, IL 60139
630-237-5000

Toll Free Customer Service and Technical Support
800-992-4657

Toll Free Fax
888-246-5732

77-2019R-4 Revisions: (P1) Added Prop 65 warning; (P3) Updated Parts List and exploded view; (P4) Updated contact information.