



MX1212

12:1 PUMP SYSTEMS FOR AIR ASSIST & AIRLESS FINISHING

Patent 7,603,855



SPECIFICATIONS	
Ratio:	12:1
Maximum air inlet pressure:	8 bar [116 psi]
Maximum fluid pressure:	96 bar [1390 psi]
Displacement per cycle:	72 cc [2.4 oz]
Output @ 60 cycles/min:	4.3 L/m [1.2 gal/m]
Air consumption @ 20 cycles/min. and 8 bar [116 psi] air inlet pressure:	147 LPM [5.2 SCFM]
Maximum recommended continuous cycle rate:	20 cycles/min
Air inlet connection:	3/8" BSP(f) and 1/4" NPS(m)
Air piston diameter:	85 mm [3.3 in]
Stroke length:	75 mm [3.0 in]
Fluid inlet connection:	3/4" NPS(m)
Fluid outlet connection:	3/8" BSP(m) / 3/8" NPS(m)
Wetted parts materials of construction:	Stainless Steel, Tungsten Carbide, Hard Chrome, PTFE, Polyethylene, Leather
Sound level:	96.2 dB

In this part sheet, the words **WARNING**, **CAUTION** and **NOTE** are used to emphasize important safety information as follows:

WARNING

Hazards or unsafe practices which could result in severe personal injury, death or substantial property damage.

CAUTION

Hazards or unsafe practices which could result in minor personal injury, product or property damage.

NOTE

Important installation, operation or maintenance information.

WARNING

Read the following warnings before using this equipment.



READ THE MANUAL

Before operating finishing equipment, read and understand all safety, operation and maintenance information provided in the operation manual.



OPERATOR TRAINING

All personnel must be trained before operating finishing equipment.



EQUIPMENT MISUSE HAZARD

Equipment misuse can cause the equipment to rupture, malfunction, or start unexpectedly and result in serious injury.



LOCK OUT / TAG-OUT

Failure to de-energize, disconnect, lock out and tag-out all power sources before performing equipment maintenance could cause serious injury or death.



AUTOMATIC EQUIPMENT

Automatic equipment may start suddenly without warning.



PRESSURE RELIEF PROCEDURE

Always follow the pressure relief procedure in the equipment instruction manual.



KEEP EQUIPMENT GUARDS IN PLACE

Do not operate the equipment if the safety devices have been removed.



KNOW WHERE AND HOW TO SHUT OFF THE EQUIPMENT IN CASE OF AN EMERGENCY



WEAR SAFETY GLASSES

Failure to wear safety glasses with side shields could result in serious eye injury or blindness.



INSPECT THE EQUIPMENT DAILY

Inspect the equipment for worn or broken parts on a daily basis. Do not operate the equipment if you are uncertain about its condition.



NEVER MODIFY THE EQUIPMENT

Do not modify the equipment unless the manufacturer provides written approval.



NOISE HAZARD

You may be injured by loud noise. Hearing protection may be required when using this equipment.

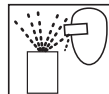

PROJECTILE HAZARD

You may be injured by venting liquids or gases that are released under pressure, or flying debris.



PINCH POINT HAZARD

Moving parts can crush and cut. Pinch points are basically any areas where there are moving parts.



STATIC CHARGE

Fluid may develop a static charge that must be dissipated through proper grounding of the equipment, objects to be sprayed and all other electrically conductive objects in the dispensing area. Improper grounding or sparks can cause a hazardous condition and result in fire, explosion or electric shock and other serious injury.



WEAR RESPIRATOR

Toxic fumes can cause serious injury or death if inhaled. Wear a respirator as recommended by the fluid and solvent manufacturer's Material Safety Data Sheet.



TOXIC FLUID & FUMES

Hazardous fluid or toxic fumes can cause serious injury or death if splashed in the eyes or on the skin, inhaled, injected or swallowed. LEARN and KNOW the specific hazards of the fluids you are using.



FIRE AND EXPLOSION HAZARD

Improper equipment grounding, poor ventilation, open flame or sparks can cause a hazardous condition and result in fire or explosion and serious injury.



MEDICAL ALERT

Any injury caused by high pressure liquid can be serious. If you are injured or even suspect an injury:

- Go to an emergency room immediately.
- Tell the doctor you suspect an injection injury.
- Show the doctor this medical information or the medical alert card provided with your airless spray equipment.
- Tell the doctor what kind of fluid you were spraying or dispensing.



GET IMMEDIATE MEDICAL ATTENTION

To prevent contact with the fluid, please note the following:

- Never point the gun/valve at anyone or any part of the body.
- Never put hand or fingers over the spray tip.
- Never attempt to stop or deflect fluid leaks with your hand, body, glove or rag.
- Always have the tip guard on the spray gun before spraying.
- Always ensure that the gun trigger safety operates before spraying.



CA PROP
65

PROP 65 WARNING

WARNING: This product contains chemicals known to the State of California to cause cancer and birth defects or other reproductive harm.

IT IS THE RESPONSIBILITY OF THE EMPLOYER TO PROVIDE THIS INFORMATION TO THE OPERATOR OF THE EQUIPMENT. FOR FURTHER SAFETY INFORMATION REGARDING THIS EQUIPMENT, SEE THE GENERAL EQUIPMENT SAFETY BOOKLET (77-5300).

Binks reserves the right to modify equipment specification without prior notice.

! WARNING



HIGH PRESSURE CAN CAUSE SERIOUS INJURY IF EQUIPMENT IS INSTALLED OR USED INCORRECTLY—READ, UNDERSTAND, AND OBSERVE ALL WARNINGS AND INSTRUCTIONS IN THIS MANUAL.

INSTALL, OPERATE OR SERVICE THIS EQUIPMENT ONLY AFTER ALL INSTRUCTIONS ARE CLEARLY UNDERSTOOD.

It is the responsibility of the employer to place this information into the hands of the operator.

! WARNING

Hazards or unsafe practices which could result in severe personal injury, death or substantial property damage.

! CAUTION

Hazards or unsafe practices which could result in minor personal injury, product or property damage.

NOTE

Important installation, operation or maintenance information.

AVOID STATIC SPARKING

1. Use Binks **NO-WIRE** conductive hose in all airless spraying operations. Be sure the gun and hose have continuity.
2. Make sure the pump is grounded. **NEVER** operate the unit when it is on a non-grounded platform.
3. When flushing or cleaning with a combustible solvent, always use an open metallic container for receiving the waste solvent. Ground the solvent receptacle.
4. **ALWAYS** remove spray tip when flushing the system. Operate the pump at the lowest possible pressure.

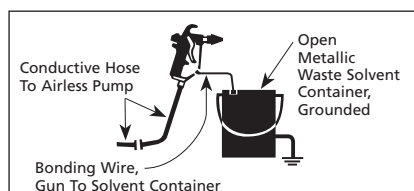

GENERAL WARNINGS

1. **NEVER** leave a pressurized sprayer unattended.
2. Periodically inspect all hoses for leaks and/or abrasions and tighten all connections before use. **DO NOT ATTEMPT TO REPAIR** a defective hose. **REPLACE** it with another conductive hose.
3. **ALWAYS** relieve pressure in the system by turning bypass valve to **BYPASS** or triggering spray gun before disassembly of any component parts.

CAUTION

Never store de-ionized, distilled, reverse osmosis or any pure grade of water in the pump. These fluids may cause corrosion.

NOTE

BINKS is not responsible for misapplication of pumps. Consult your BINKS representative for application assistance.

NOTE

Be sure that all fluids, solvents and fillers to be used are chemically and physically compatible with wetted parts in the pump. Consult your BINKS representative for pump materials of constructions and compatibility information. Consult the fluid manufacturer for information regarding the fluids to be used.

REPLACEMENT PARTS

The pump is designed to use authorized parts only. When using this pump with parts that do not comply with the minimum specifications and safety devices of Binks, the user assumes all risks and liabilities.

! WARNING

EXCESSIVE AIR PRESSURE

Can cause personal injury, pump damage or property damage. Do not exceed maximum inlet air pressure as stated on motor model plate.

HAZARD	CAUSE	SAFEGUARDS
<p>EXPLOSION</p> 	<p>STATIC ELECTRICITY</p> <p>Use of this equipment in a potentially explosive atmosphere.</p> <p>Vapors from flammable liquids can catch fire or explode from static electricity discharges.</p>	<ol style="list-style-type: none"> 1. If installing this equipment in a potentially explosive atmosphere, check the ATEX equipment category and temperature ratings meet the requirements for the zoned area. 2. Check electrical continuity of the air supply to earth — should be no greater than $10^6 \Omega$. 3. Electrically bond all metallic equipment to earth. Should be no greater than 1Ω.
<p>SPECIAL CONDITIONS FOR SAFE USE REQUIRED BY ATEX CERTIFICATION</p>	<p>Over pressurization of equipment can cause equipment failure or injury.</p> <p>Use lubricating medium resistant to carburisation.</p> <p>Improper operation or maintenance may create a hazard.</p>	<ol style="list-style-type: none"> 1. Do not exceed the stated maximum working pressures and motor speed as specified in this manual. 2. Only a suitably approved static dissipating or conductive air supply hoses shall be attached to the equipment and terminated to the air supply. 3. Air supplies (compressors, etc.) shall be sited in a non-hazardous area with a filter on the air intake system to prevent the ingress of dust or similar foreign material into the parts where compression takes place. 4. Use lubricating medium resistant to carburisation and has an auto ignition temperature of more than 185°C for T4 equipment. 5. User shall ensure all metallic parts of the equipment are suitably bonded to earth. Should be no greater than 1Ω.

STARTUP AND OPERATION

(Part numbers referenced are contained in MX1212 Bare Pump Assembly Part Sheet: 77-2916.)

GROUNDING THE BINKS PUMP

⚠ WARNING

To prevent static charging igniting the flammable spray material, the BINKS pump must be grounded before it is started up. A grounding cable is included with the pump.

1. Clamp the grounding cable to the terminal on the high pressure filter or the air motor.
2. Connect the other end of the grounding cable to a suitable grounding device (e.g. grounding bar).

PREPARING TO START UP THE BINKS PUMP

Proceed as follows:

1. Check that the solvent cup is full to the level shown. If necessary, add material to the solvent cup. (Order part no. 0114-009433 for solvent based paint, and part no. 0114-014871 for waterborne paint.)
- 
2. Select a suitable filter element using the table in this manual (page 9) and insert it into the high pressure filter.
 3. Attach a suitable fluid hose to the outlet fitting on the high pressure filter.

⚠ WARNING

The fluid hose supplied by BINKS is identified with the maximum permitted working pressure and the bursting pressure. The lesser value—the maximum permitted working pressure—must be greater than the maximum permitted working pressure of the pump.

4. Connect the gun—designed at least for the maximum permitted working pressure of the pump—to the fluid hose.
5. Make sure that the ball valve on the air control assembly is closed.
6. Connect the compressed air supply to the air inlet connection.
7. The pump is equipped with an air pressure regulator. Before putting the

pressure line into operation, relieve the pressure regulator by fully unscrewing the regulating screw. Thereafter rotate the regulating screw clockwise until the pressure gauge on the regulator indicates the required pressure.

NOTE

The pump is equipped with an air pressure safety valve set at 8 bar (116 psi).

RINSING THE BINKS PUMP

⚠ WARNING

Wear eye protection.

Every BINKS pump is tested with water during final inspection and thoroughly rinsed with a non-gumming preservative oil. With this rinsing process, it is possible that the residual moisture of water emulsion will be left in the pump.

Before the unit is started up for the first time, a suitable solvent must be used to thoroughly rinse out the remains of the preservative fluid and the unavoidable impurities introduced during equipment assembly.

Proceed as follows:

1. Prepare the BINKS pump for start-up as shown above.
2. Close the high pressure ball valve on the fluid filter.
3. Immerse the siphon kit in the tank of solvent.
4. Insert the return flow hose into the tank of solvent. Open the high pressure ball valve on the fluid filter.
5. Open the air control ball valve and set the air regulator to approximately 1 bar (14.5 psi). The siphon kit now draws in the solvent. The solvent runs back to the solvent tank through the high pressure fluid filter, the high pressure ball valve and the return flow hose.
6. Remove the spray tip from the gun and point the gun into the tank. Unlock the safety lever on the gun, operate the gun and close the high pressure ball valve. The solvent will now flow through the high pressure fluid filter, the fluid hose and the gun, back into

the tank. The time of rinsing depends on the length of the material lines and the solubility of the spray material. We recommend a short reflux with "fresh" solvent.

7. Release the gun trigger.
8. Slowly increase the pressure at the regulator to maximum working pressure while checking and testing that all lines and screw and plug caps are tightly sealed. If there are any leaks in the system, shut down the BINKS pump immediately. Only restart the BINKS pump once you have repaired the leak.
9. Reduce the air pressure at the air regulator again and close the ball valve.
10. Make sure that the return flow hose is still directed into the solvent tank. Carefully open the high pressure ball valve to reduce the pressure in the fluid hose and in the high pressure filter.
11. Point the gun into the tank of solvent and operate the trigger, to reduce any pressure which may still exist in the fluid hose and in the gun.

⚠ CAUTION

If working with waterborne material, the BINKS pump must again be thoroughly rinsed with water before it is started up.

START-UP

1. Prepare the BINKS pump for start-up as shown above and if necessary, rinse pump.
2. Close the high pressure ball valve on the fluid filter.
3. Immerse the siphon kit in the spray material to be used.
4. Place the return flow hose in the tank. Then open the high pressure ball valve.
5. Open the ball valve for the compressed air supply and use the pressure regulator to set the compressed air supply to 1 bar (14.5 psi). The pump will now draw in the spray material. The spray material

(continued on next page)

STARTUP AND OPERATION

flows back into the tank through the high pressure filter, the high pressure ball valve and the return pipe.

- Remove the spray tip from the gun and point the gun into the tank. Unlock the safety lever on the gun. Operate the gun trigger and close the high pressure ball valve. The spray material will now flow through the high pressure filter, the fluid hose and the gun, back into the tank.
- Release the gun trigger and set the working pressure at the regulator.

NOTE

Before carrying out any coating work, we recommend a test spray (e.g. on to paper or wood). Only if the test gives you the desired result should you start to coat the actual object.

WORK STOPPAGES

CAUTION

If working with 2-K spray material, you must note the given pot life and follow it precisely. Within this time, the unit must be carefully cleaned and rinsed with the recommended solvent. There must be no residue left in the pump, the high pressure filter or the gun.

CAUTION

When work is stopped, the safety lever of the gun must be locked.

For work stoppages of between 10 and 30 minutes, please proceed as follows:

WARNING

Wear eye protection.

- Lock the safety lever on the gun.
- Shut off the compressed air supply by closing the ball valve.
- Briefly open the high pressure ball valve, taking care that the return flow hose is not pointed at other people or at yourself, until the pressure has reduced. Then close the high pressure ball valve again.
- Clean the outside of the spray nozzle from spray material residue.

SHUT-DOWN

CAUTION

Once work is completed, the BINKS pump must be thoroughly cleaned. Under no circumstances must you allow paint residue to dry out in the unit. To clean the pump, use a solvent appropriate to the spray material.

WARNING

Wear eye protection.

- Close the ball valve for the compressed air supply.
- Make sure that the flow hose is still directed into the spray material tank. Carefully open the high pressure ball valve to reduce the pressure in the pump and in the high pressure filter.
- Remove the spray tip from the gun.
- Point the gun into the tank of spray material and operate the trigger to reduce any pressure which may still exist in the fluid hose and in the gun.
- Lock the safety lever on the gun.
- Remove the siphon kit from the spray material.

CLEANING YOUR BINKS PUMP

CAUTION

Do not allow spray material or solvent to soak into the ground.

WARNING

Wear eye protection.

- Clean the pump and the siphon kit from the outside. Immerse the suction system in the tank of solvent.
- Clean the fluid tip/tip system as described in the service bulletin of the spray gun. We recommend to soak the fluid tip in solvent.
- Unlock the safety lever of the gun without fluid tip. Operate the gun. Close the high pressure ball valve. Set the air inlet pressure to 1 bar (14.5 psi) and slowly open the ball valve. Let the solvent run through the system so that the spraying material can rinse out.
- Let the solvent run through the system for a couple of minutes until the solvent runs clear through the gun. Close the ball valve and lock the safety lever of the gun.
- Clean the gun from the outside and check the filter on the handle (if mounted).
- Clean the filter element of the high pressure filter.
- Clean the filter of the siphon kit.
- We recommend keeping the pump filled with liquid.

NOTE

If the pump is not to be used for longer periods of time, we recommend flushing the system with a light, silicone-free oil.

MX1212 CART MOUNTED SYSTEMS

MX1212

SEALS

PL = PTFE / Leather
 PP = PTFE
 PU = PTFE / UHMW
 UC = U-Cups

SPRAY GUN

0 = none
 E = AA1600 Flat Tip
 F = AA1600 Twist Tip
 P = Airless 75
 Q = TROPHY AA 1600 Flat Tip
 R = TROPHY AA 1600 Twist Tip

AIR CONTROL

0 = none
 D = Air Control

FILTER

0 = none
 1 = 100 mesh
 2 = 200 mesh

SIPHON

0 = none
 S = 5 gallon
 T = 55 gallon

HOSE

00 = none
 25 = 25 ft / whip
 50 = 50 ft / whip

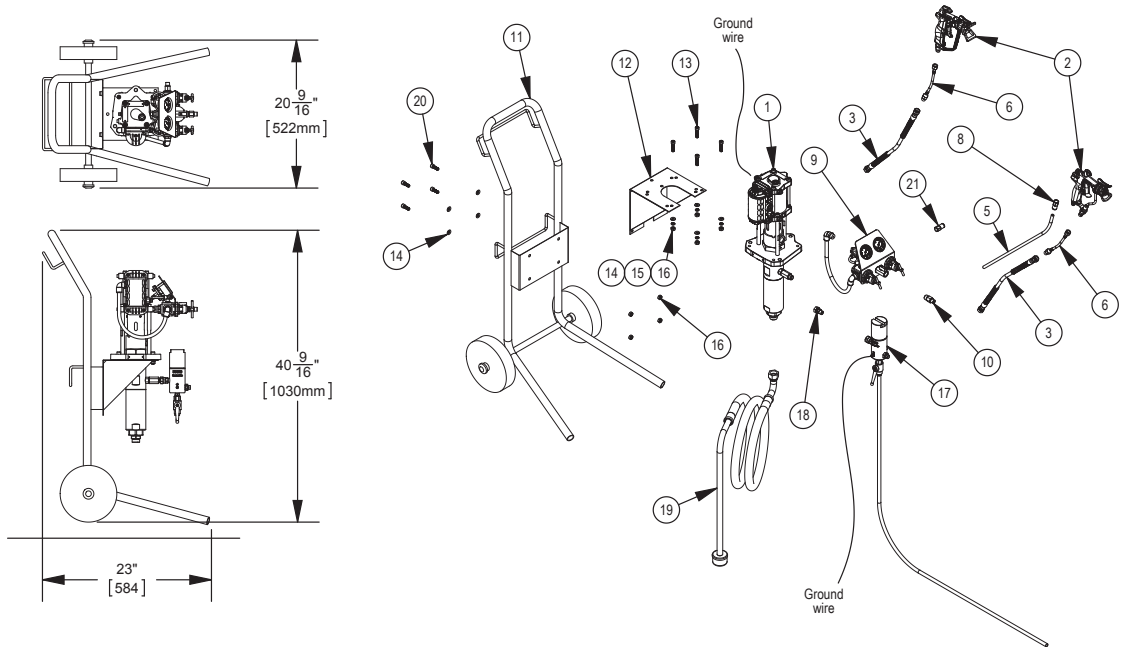

SYSTEM COMPONENT LIST

ITEM NO.	PART NUMBER	DESCRIPTION	QTY	PART SHEET
1	MX1212PL	BARE PUMP ASSEMBLY (PTFE/LEATHER)	1 IF SEAL TYPE = PL	77-2916
	MX1212PP	BARE PUMP ASSEMBLY (PTFE)	1 IF SEAL TYPE = PP	
	MX1212PU	BARE PUMP ASSEMBLY (PTFE/UHMW)	1 IF SEAL TYPE = PU	
	MX1212UC	BARE PUMP ASSEMBLY (U-CUPS)	1 IF SEAL TYPE = UC	
2	0909-1600-HF1310	AA1600 GUN ASSEMBLY (1310 FLAT TIP)	1 IF GUN TYPE = E	77-2921
	0909-1600-HT0613	AA1600 GUN ASSEMBLY (613 TWIST TIP)	1 IF GUN TYPE = F	
	1600-HF1310	TROPHY AA1600 GUN ASSEMBLY (1310 FLAT TIP)	1 IF GUN TYPE = Q	77-3130
	1600-HT0613	TROPHY AA1600 GUN ASSEMBLY (613 TWIST TIP)	1 IF GUN TYPE = R	
	0811-7500-1	AIRLESS 75 GUN ASSEMBLY	1 IF GUN TYPE = P	77-2950
3	71-4995	MATERIAL HOSE (3/16" ID X 25', 1900 PSI)	1 IF HOSE LENGTH = 25 2 IF HOSE LENGTH = 50	
4	72-791	DM NIPPLE (1/4" NPS, SS) [NOT SHOWN]	1 IF HOSE LENGTH = 50	
5	71-4803	AIR HOSE (3/8" OD TUBE X 28FT)	1 IF HOSE LENGTH = 25	
	71-4804	AIR HOSE (3/8" OD TUBE X 53FT)	1 IF HOSE LENGTH = 50	
6	71-6844	MATERIAL HOSE (1/8" ID X 3', 5000 PSI)	1 IF HOSE LENGTH = 25 / 50	
7	72-2332	SWIVEL ADAPTER (1/4" NPS M X F) [NOT SHOWN]	1 IF GUN TYPE = P	
8	54-4976	ADAPTER FITTING (3/8" OD TUBE X 1/4" NPS F)	1 IF GUN TYPE = E / F	
9	0115-010180	AIR CONTROL ASSEMBLY	1 IF AIR CONTROL = D	
10	83-4233	DM NIPPLE (1/4" NPS/NPT X 3/8" NPS/NPT)	1 IF AIR CONTROL = D	
11	0115-010186	TROLLEY ASSEMBLY	1	
12	0115-010179	PUMP BRACKET	1	
13	0115-010001	SOCKET HEAD CAP SCREW (M8 X 35mm)	4	
14	0115-010030	HEX NUT (M8)	8	
15	0115-010031	LOCK WASHER (M8)	4	
16	0115-010035	FLAT WASHER (M8)	8	
17	0115-010326	S.S. FILTER ASSEMBLY (100 MESH)	1 IF FILTER TYPE = 1	
	0115-010630	S.S. FILTER ASSEMBLY (200 MESH)	1 IF FILTER TYPE = 2	
18	103-1238	SWIVEL ADAPTER (3/8" NPS F X 1/4" NPT/NPS M)	1 IF NO FILTER	
19	41-17262	SIPHON TUBE ASSEMBLY (5 GALLON)	1 IF SIPHON SIZE = S	
	0115-010381	SIPHON TUBE ASSEMBLY (55 GALLON)	1 IF SIPHON SIZE = T	
20	0115-010227	SOCKET HEAD CAP SCREW (M8 X 25)	4	
21	85-521	SWIVEL ELBOW (3/8" OD TUBE X 1/4" NPT)	1 IF AIR CONTROL = D	

MX1212 WALL MOUNTED SYSTEMS

MX1212

W

SEALS

PL = PTFE / Leather
 PP = PTFE
 PU = PTFE / UHMW
 UC = U-Cups

SPRAY GUN

0 = none
 E = AA1600 Flat Tip
 F = AA1600 Twist Tip
 P = Airless 75
 Q = TROPHY AA 1600 Flat Tip
 R = TROPHY AA 1600 Twist Tip

AIR CONTROL

0 = none
 D = Air Control

FILTER

0 = none
 1 = 100 mesh
 2 = 200 mesh

SIPHON

0 = none
 S = 5 gallon
 T = 55 gallon

HOSE

00 = none
 25 = 25 ft / whip
 50 = 50 ft / whip

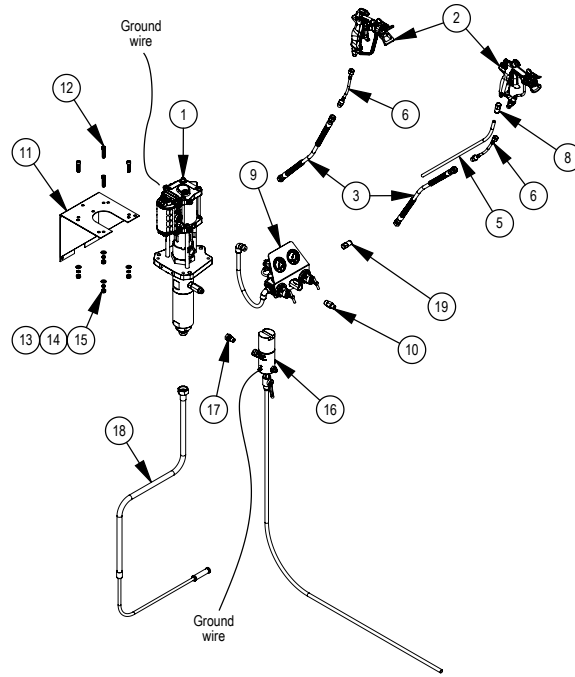
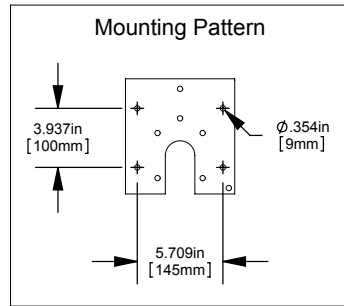
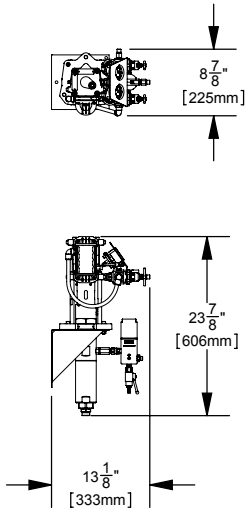

SYSTEM COMPONENT LIST

ITEM NO.	PART NUMBER	DESCRIPTION	QTY	PART SHEET
1	MX1212PL	BARE PUMP ASSEMBLY (PTFE/LEATHER)	1 IF SEAL TYPE = PL	77-2916
	MX1212PP	BARE PUMP ASSEMBLY (PTFE)	1 IF SEAL TYPE = PP	
	MX1212PU	BARE PUMP ASSEMBLY (PTFE/UHMW)	1 IF SEAL TYPE = PU	
	MX1212UC	BARE PUMP ASSEMBLY (U-CUPS)	1 IF SEAL TYPE = UC	
2	0909-1600-HF1310	AA1600 GUN ASSEMBLY (1310 FLAT TIP)	1 IF GUN TYPE = E	77-2921
	0909-1600-HT0613	AA1600 GUN ASSEMBLY (613 TWIST TIP)	1 IF GUN TYPE = F	77-3130
	1600-HF1310	TROPHY AA1600 GUN ASSEMBLY (1310 FLAT TIP)	1 IF GUN TYPE = Q	
	1600-HT0613	TROPHY AA1600 GUN ASSEMBLY (613 TWIST TIP)	1 IF GUN TYPE = R	
	0811-7500-1	AIRLESS 75 GUN ASSEMBLY	1 IF GUN TYPE = P	77-2950
3	71-4995	MATERIAL HOSE (3/16" ID X 25', 1900 PSI)	1 IF HOSE LENGTH = 25 2 IF HOSE LENGTH = 50	
4	72-791	DM NIPPLE (1/4" NPS, SS) [NOT SHOWN]	1 IF HOSE LENGTH = 50	
5	71-4803	AIR HOSE (3/8" OD TUBE X 28FT)	1 IF HOSE LENGTH = 25	
	71-4804	AIR HOSE (3/8" OD TUBE X 53FT)	1 IF HOSE LENGTH = 50	
6	71-6844	MATERIAL HOSE (1/8" ID X 3', 5000 PSI)	1 IF HOSE LENGTH = 25 / 50	
7	72-2332	SWIVEL ADAPTER (1/4" NPS M X F) [NOT SHOWN]	1 IF GUN TYPE = P	
8	54-4976	ADAPTER FITTING (3/8" OD TUBE X 1/4" NPS F)	1 IF GUN TYPE = E / F	
9	0115-010180	AIR ASSIST AIR CONTROL ASSEMBLY	1 IF AIR CONTROL = D	
10	83-4233	DM NIPPLE (1/4" NPS/NPT X 3/8" NPS/NPT)	1 IF AIR CONTROL = D	
11	0115-010179	PUMP BRACKET	1	
12	0115-010001	SOCKET HEAD CAP SCREW (M8 X 35mm)	4	
	0115-010030	HEX NUT (M8)	4	
14	0115-010031	LOCK WASHER (M8)	4	
15	0115-010035	FLAT WASHER (M8)	4	
16	0115-010326	S.S. FILTER ASSEMBLY (100 MESH)	1 IF FILTER TYPE = 1	
	0115-010630	S.S. FILTER ASSEMBLY (200 MESH)	1 IF FILTER TYPE = 2	
17	103-1238	SWIVEL ADAPTER (3/8" NPS F X 1/4" NPT/NPS M)	1 IF NO FILTER	
18	41-17262	SIPHON TUBE ASSEMBLY (5 GALLON)	1 IF SIPHON SIZE = S	
	0115-010381	SIPHON TUBE ASSEMBLY (55 GALLON)	1 IF SIPHON SIZE = T	
19	85-521	SWIVEL ELBOW (3/8" OD TUBE X 1/4" NPT)	1 IF AIR CONTROL = D	

STAINLESS STEEL HIGH PRESSURE FILTER ASSEMBLIES

0115-010326 (100 MESH FILTER ELEMENT)

0115-010630 (200 MESH FILTER ELEMENT)

SPECIFICATIONS	
Max working pressure:	272 bar [3945 psi]
Fluid inlet connection:	3/8" BSP (f)
Fluid outlet connection:	1/4" NPS (m)
Wetted parts materials of construction:	Stainless Steel, PTFE

Additional filter mesh sizes (sold separately):
For 50 mesh order: 0110-009131

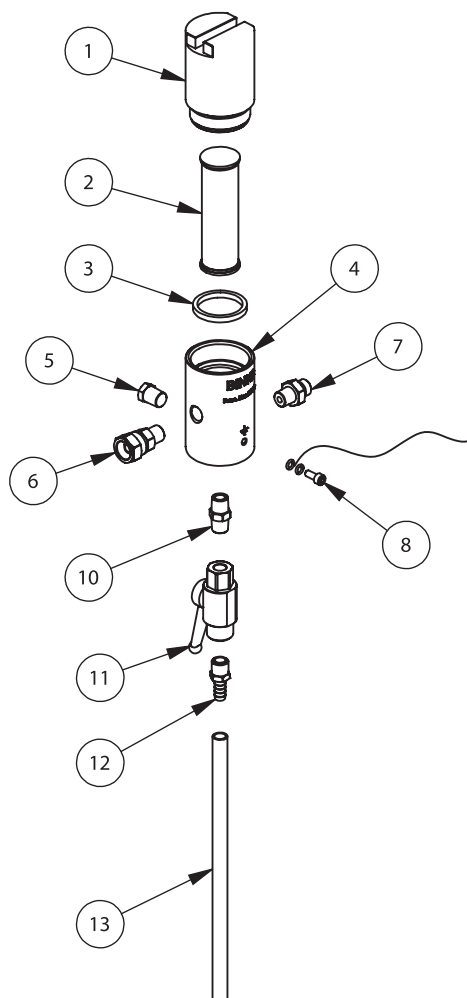

PARTS LIST

ITEM NO.	PART NUMBER	DESCRIPTION	0115-010326 QTY	0115-010630 QTY
1	0115-010399	FILTER CAP	1	1
2	0110-009134	200 MESH FILTER ELEMENT	0	1
	0110-009132	100 MESH FILTER ELEMENT	1	0
3	0114-016061	GASKET	1	1
4	0115-010398	FILTER HOUSING	1	1
5	0115-010600	PLUG	1	1
6	0114-016058	SWIVEL CONNECTING NIPPLE	1	1
7	0114-016059	OUTLET SCREW	1	1
8	0114-016243	GROUND SCREW KIT	1	1
10	0114-019090	OUTFLOW FITTING	1	1
11	0114-019091	HIGH PRESSURE BALL VALVE	1	1
12	0114-019985	HOSE CONNECTION	1	1
13	0115-010327	FILTER DRAIN HOSE	1	1

SYSTEM ACCESSORIES

0115-010381 55-GALLON SIPHON KIT
and
41-17262 5-GALLON SIPHON KIT

PARTS LIST

When ordering, please specify Part No.

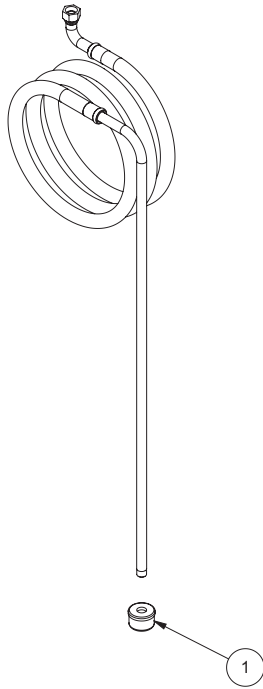

ITEM NO.	PART NO.	DESCRIPTION	QTY.
1	41-2661	1/2 NPSM x 30 MESH S.S. STRAINER.	1

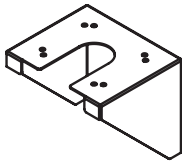
ACCESSORIES FOR YOUR MX1212 PUMP

BRACKET
0115-010179

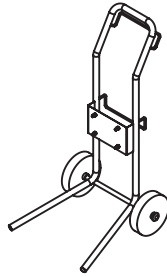

TROLLEY ASSEMBLY
0115-010186



FLUID FILTER (100 MESH)
0115-010326

FLUID FILTER (200 MESH)
0115-010630



SIPHON KITS
41-17262 (5 GAL)
0115-010381 (55 GAL)

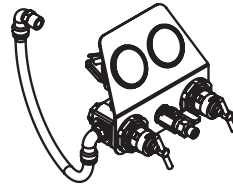

AIR CONTROLS
0115-010180



**LUBRICATING OIL FOR
FX12 FLUID PUMP**
0114-009433 (Solvent Based Materials)
0114-014871 (Water Based Materials)

WARRANTY POLICY

Binks products are covered by Carlisle Fluid Technologies one year materials and workmanship limited warranty. The use of any parts or accessories, from a source other than Carlisle Fluid Technologies, will void all warranties. For specific warranty information please contact the closest Carlisle Fluid Technologies location listed below.

Carlisle Fluid Technologies reserves the right to modify equipment specifications without prior notice. DeVilbiss®, Ransburg®, ms®, BGK®, and Binks® are registered trademarks of Carlisle Fluid Technologies, Inc.

©2018 Carlisle Fluid Technologies, Inc.
All rights reserved.

Binks is part of Carlisle Fluid Technologies, a global leader in innovative finishing technologies. For technical assistance or to locate an authorized distributor, contact one of our international sales and customer support locations.

USA/Canada

info@carlisleleft.com
Tel: 1-888-992-4657
Fax: 1-888-246-5732

China

mkt@carlisleleft.com.cn
Tel: +8621-3373 0108
Fax: +8621-3373 0308

Germany

info@carlisleleft.eu
Tel: +49 (0) 6074 403 1
Fax: +49 (0) 6074 403 281

United Kingdom

info@carlisleleft.eu
Tel: +44 (0)1202 571 111
Fax: +44 (0)1202 573 488

Mexico

ventas@carlisleleft.com.mx
Tel: +52 55 5321 2300
Fax: +52 55 5310 4790

Australia

sales@carlisleleft.com.au
Tel: +61 (0) 2 8525 7555
Fax: +61 (0) 2 8525 7575

Japan

overseas-sales@carlisleleft.co.jp
Tel: +81 45 785 6421
Fax: +81 45 785 6517

For the latest information about our products, visit www.carlisleleft.com.