

BINKS Ram Unit

FLUID HANDLING

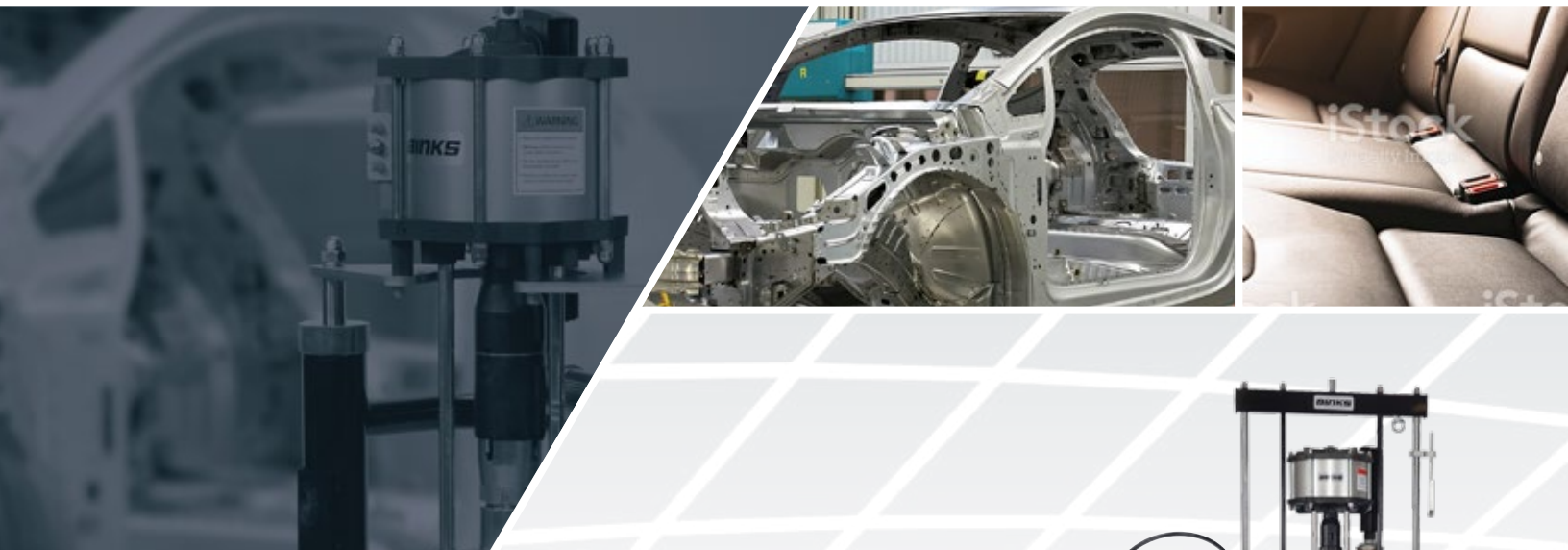

**High Performance
Ram Units**
Lower Cost of Ownership



BINKS Ram Unit Packages

Binks new range of Ram Units offer a reliable and higher performance solution for the delivery of medium and high viscosity materials. Binks Ram Units provide the ideal delivery solution for materials such as lubricants, mastics, adhesives, epoxies, and sealants. They deliver a constant, low pulse flow of materials to the dispensing tool by ensuring correct priming of the pump and preventing material cavitation.

Complete Ram Units include an easy-use pneumatic control box with up/down switch, auto shut off when the container is empty and a release valve to break the suction seal when lifting the ram plate clear of the used material. Optional extras include an automatic Change Over switch for use with two Ram Units.

- Wide choice of pump ratios from 8:1 to 60:1 (ball-check) and 5:1 to 68:1 (chop-check)
- Patented Binks low-ice motors provide non-stop performance
- Pump rod and packings last up to 3X longer than the competition
- Stainless Steel pump fluid section as standard

RAM PACKAGES

SR20

Single Post Ram Unit with 3" pneumatic rams and 5 Gallon/20L Follower Plate.

6 pump options.

Cart mounted version available.

DR20

Dual Post Ram Unit with 3" pneumatic rams and 5 Gallon/20L Follower Plate.

13 pump options.

DR30

Dual Post Ram Unit with 3" pneumatic rams and 7.5 Gallon/30L Follower Plate.

13 pump options.

DR60

Dual Post Ram Unit with 3" pneumatic rams and 15 Gallon/60L Follower Plate.

13 pump options.

DR205

Dual Post Ram Unit with 3" pneumatic rams and 55 Gallon/205L Follower Plate.

24 pump options.

DRX205

Dual Post Extreme Duty Ram Unit with 6" pneumatic rams and 55 Gallon/205L/15 Gallon/60L Follower Plate.

24 pump options.

DRI205

Dual Post Air Intensified Ram and 55 Gallon/205L Follower Plate.

24 pump options.

Ram Unit Pump Outfit Options

Equip your Ram Unit from our extensive range of durable, hard-working MX Pumps. (See back page for pump fluid output and pressure ratings)

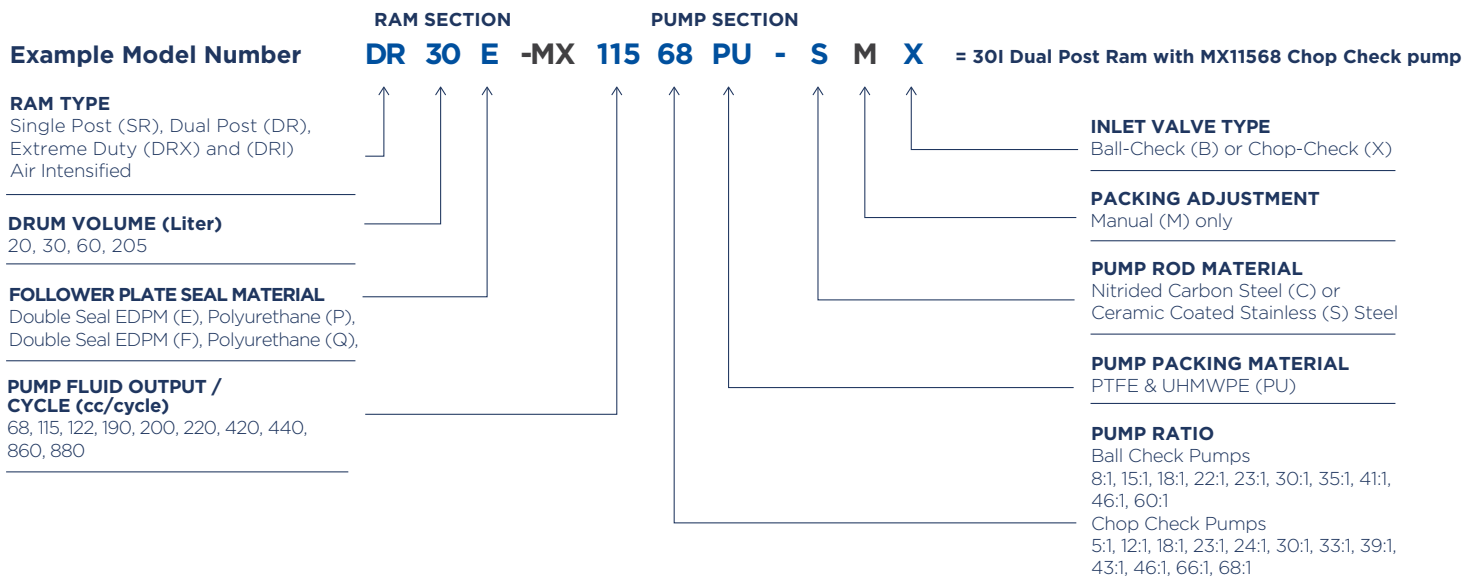

BINKS Ram Unit

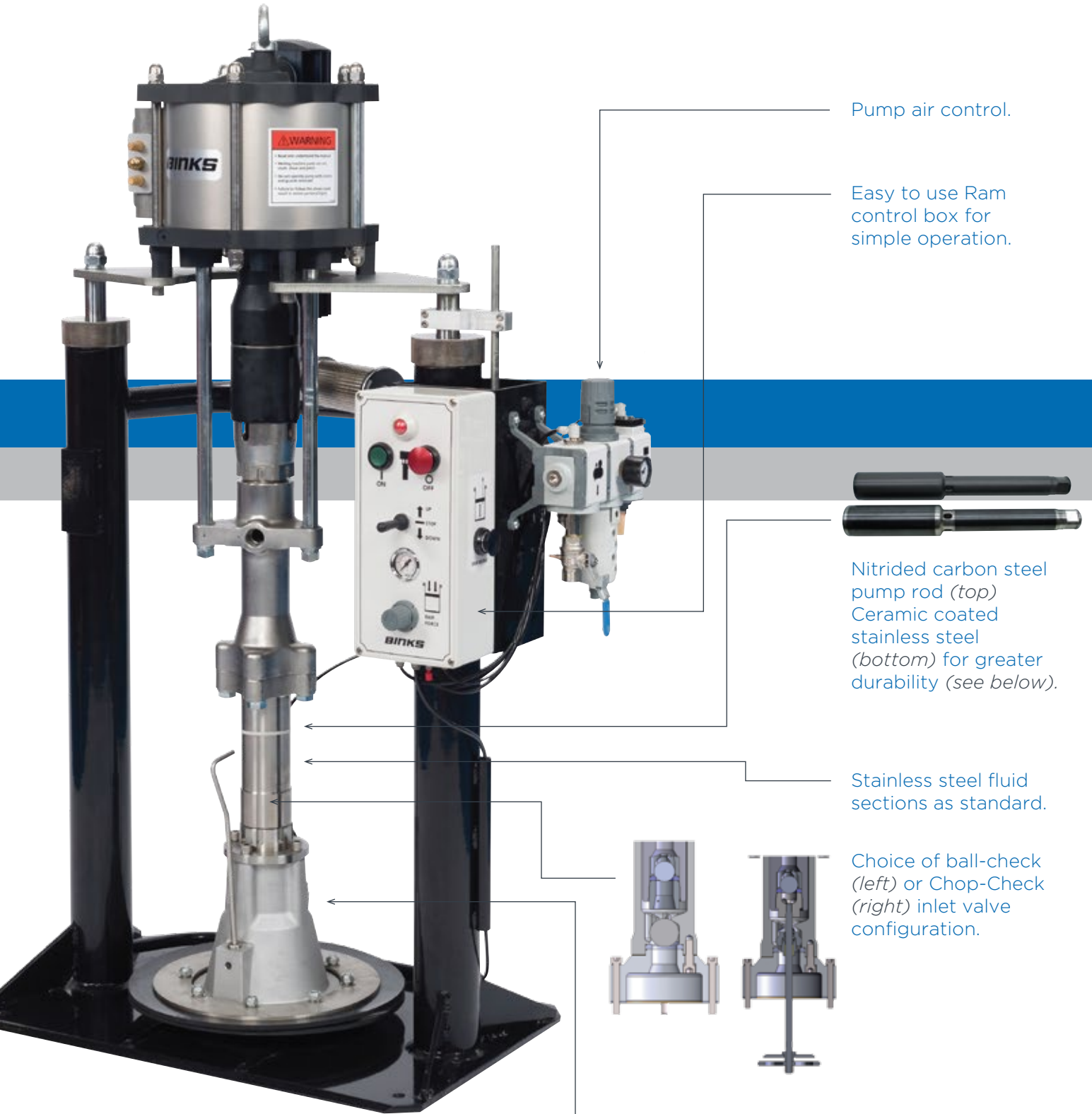

Pump air control.

Easy to use Ram control box for simple operation.



Nitrided carbon steel pump rod (*top*)
Ceramic coated stainless steel (*bottom*) for greater durability (see below).

Stainless steel fluid sections as standard.

Choice of ball-check (*left*) or Chop-Check (*right*) inlet valve configuration.

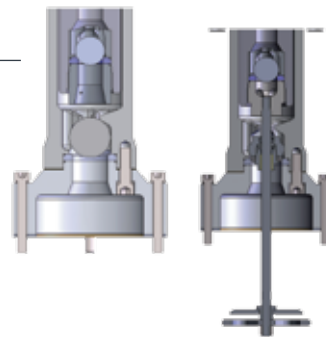

Follower plates include priming port and release valve for fast container change-over.

Ram Unit Ball-Check Pump Options

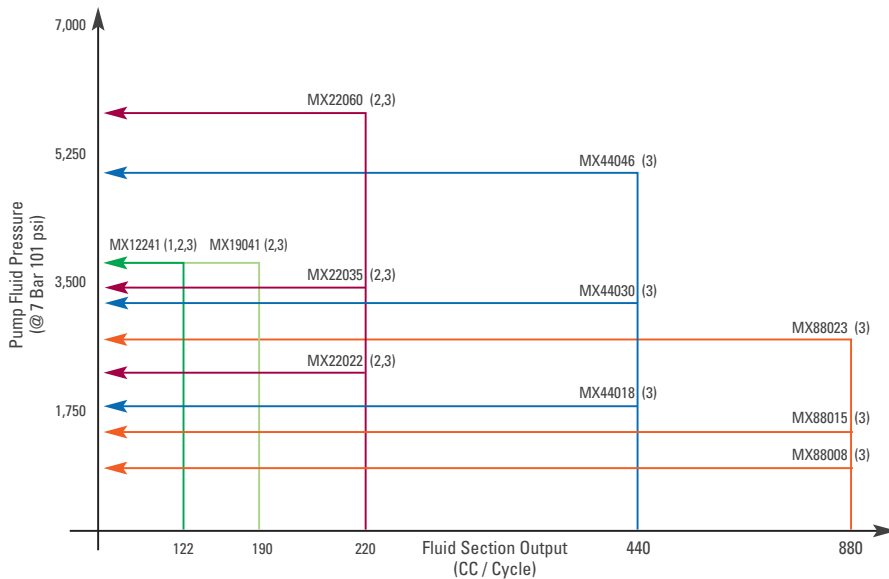

Maximum Working Air Pressure	6 Bar / 87 psi	
Air Inlet	1/2" BSP F	
Ram Stroke	SR20	410 mm / 16"
	DR20/30/60	688 mm / 27"
	DR205	960 mm / 37.8"
	DRX205	960 mm / 37.8"
Unit Height - Fully Extended	SR20	1242 mm / 49"
	DR20/30/60	1750 mm / 69"
	DR205 DRX205	2550 mm / 100"
Wiper Ring Material	SR20	EPDM / PU
	DR205 DRX205	EDPM
	SR20	55 kg / 121 lbs
Weight without Pump	DR20/30/60	130 kg / 286 lbs
	DR205	212 kg / 466 lbs
	DRX205	212 kg / 466 lbs

Ram Unit Chop-Check Pump Options

KEY:
 1 = Available on SR20
 2 = Available on DR20, DR30, DR60
 3 = Available on DR205 & DRX205

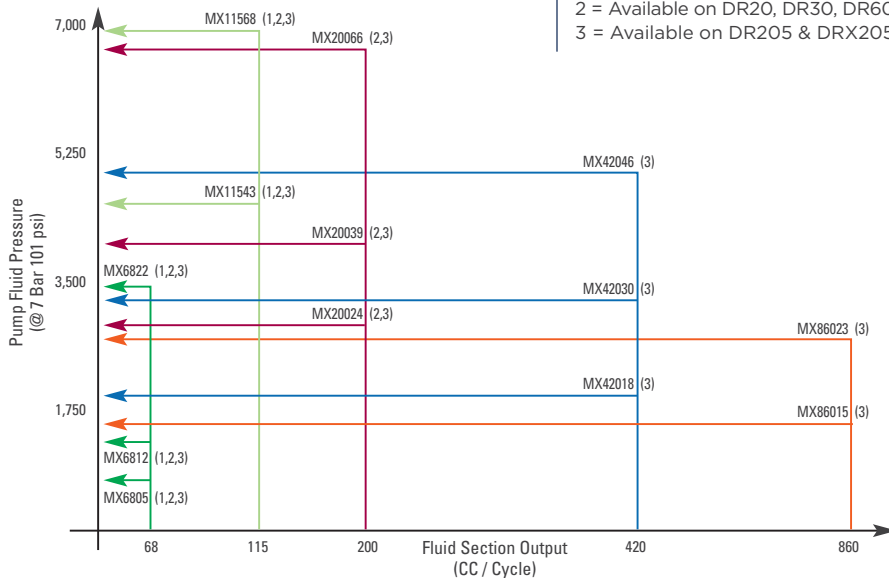

BINKS DX SERIES PUMP 5-YEAR WARRANTY

BINKS® warrants to the original end-user purchaser that Binks® Ram-Unit products shall not fail under normal use and service due to a defect in material or workmanship within five (5) years from the date of shipment from Binks®. Does not include normal wear and tear.

