

CET

Coating Equipment Technology, Inc
Quality Spray Equipment. World Class Service.

C.A. Technologies

CA Tech Lynx L200C Spray Gun

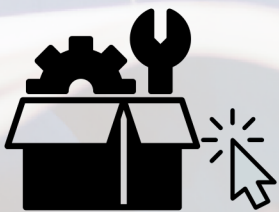

CLICK-N-PICK SPARE PARTS CUTSHEET

Easily find spare parts without digging through the full manual.

[Click on part numbers to order.](#)

BINKS



C.A. Technologies

DEVILBISS

SCHULZ

ENHANCED *INTERACTIVE* MANUAL

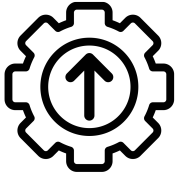

BLUE TEXT = CLICK TO ORDER



DISTRIBUTED BY COATING EQUIPMENT TECHNOLOGY, INC

PHONE: 586-210-0555

WEB: www.cetinc.com

CONVENTIONAL AIR CAP AND FLUID NOZZLE CHART

MODEL NO.	AIR CAPS	Press / Siphon	*SUGGESTED GUN INLET PRESS.	FAN CONTROL	SCFM	AIR CAP RING	AVAILABLE FLUID NOZZLES	NEEDLES / marking on needle	
L200C	22-2030	siphon	50	60-1500	12	included			
	22-2058	p & s	40		6		32-0611 1.1mm (.042")	40-1211 (211)	
	22-2080	siphon	60		14		32-0614 1.4mm (.055")	40-1214 (214)	
	22-2062**	pressure	80		19		32-0618 1.8mm (.070")	40-1218 (218)	
	22-2064**	pressure	80		22		32-0618V 1.8mm (.070")	40-5301	
	22-2704	pressure	70		21		32-0818 1.8mm (.070")	40-1222 (222)	
	22-2765	pressure	80		22		32-0622 2.2mm (.086")		
	22-2777	pressure	70		23		22-1001	32-0622V 2.2mm (.086")	40-5301
	22-2797	pressure	70		21		22-1001	32-0628 2.8mm (.110")	40-1228 (228)
	22-2880	siphon	60		15		included	32-0628V 2.8mm (.110")	40-5301
22-2900	siphon	45	12	22-1001					

Actual fluid nozzle and air cap combinations are determined by application (see application chart page 4)

*Gun inlet pressures may vary as required by application

**Air caps available with teflon coating ([22-2062T](#) & [22-2064T](#))

Operation and Maintenance Instructions for *L2000* Spray Guns

Operation

1. Connect air supply hose at handle of gun.
2. Connect a pressurized fluid supply or paint siphon cup to the gun fluid inlet.
3. Fluid flow can be controlled using the fluid control knob, this restricts flow by limiting needle travel. It is best to control fluid flow by proper selection of fluid orifice size and use the fluid control knob to “fine tune flow rate”.
4. Fan width can be adjusted using the fan control knob. Turning the knob clockwise narrows the fan.

Maintenance

IMPORTANT! Routine cleaning and maintenance is essential to insure proper gun operation.

Several states prohibit spraying solvent into the atmosphere and require the use of covered gun cleaner.

1. If a gun cleaner is being used, connect and clean the gun in the gun cleaner according to the manufactures instructions.
2. If a gun cleaner is not being used:
Remove air cap and clean separately using clean solvent.
For pressure setups, connect a pressurized solvent supply to the fluid inlet, trigger the gun allowing solvent to flow thru the gun until clean.
For siphon setups, first clean the siphon cup thoroughly then spray clean solvent thru the gun until clean.

NOTE: Gun head disassembly is not recommended for normal cleaning and maintenance.

Gun head disassembly and reassembly instructions:

Have repair kit # 10-106 available before gun disassembly.

Gun head disassembly

To remove the nozzle carrier (5) and air cap adapter (6):

1. Remove the air cap (1), fluid nozzle tip (2), fluid nozzle body (3), and needle (13).
2. Remove the needle seal cartridge (23).
3. Loosen the locknut (9) and remove fluid inlet (10) using a 5/8” open-end wrench.
4. The nozzle carrier (5) and air cap adapter (6) will now slide forward from the gun body (11).

Gun head reassembly

1. Install a new o-ring (7) on the air cap adapter (6).
2. Install o-ring (4) between fluid nozzle body (3) and fluid nozzle carrier (5).
3. Install the thread locknut (9) onto the fluid inlet (10) as far as possible.
4. Install a new fluid inlet seal (8) into the recess area on the nozzle carrier (5) inlet port.
5. Slide the nozzle carrier (5) into air cap adapter (6) and insert into the gun body (11) as far as possible. Be sure the nozzle carrier (5) extends into the hole at the back of the gun head. Install the needle seal (23) but do not tighten.
6. Rotate the nozzle carrier (5) until the fluid inlet port in the nozzle carrier (5) is aligned with the threaded hole in the body. While in this position, insert the fluid inlet (10) and tighten firmly.
7. Tighten the needle seal (23) to approx. 12 ft.-lb. torque.
8. Tighten the fluid inlet (10) to approx. 25 ft.-lb. torque.
9. Tighten the locknut (9) to approx. 33 ft.-lb. torque.

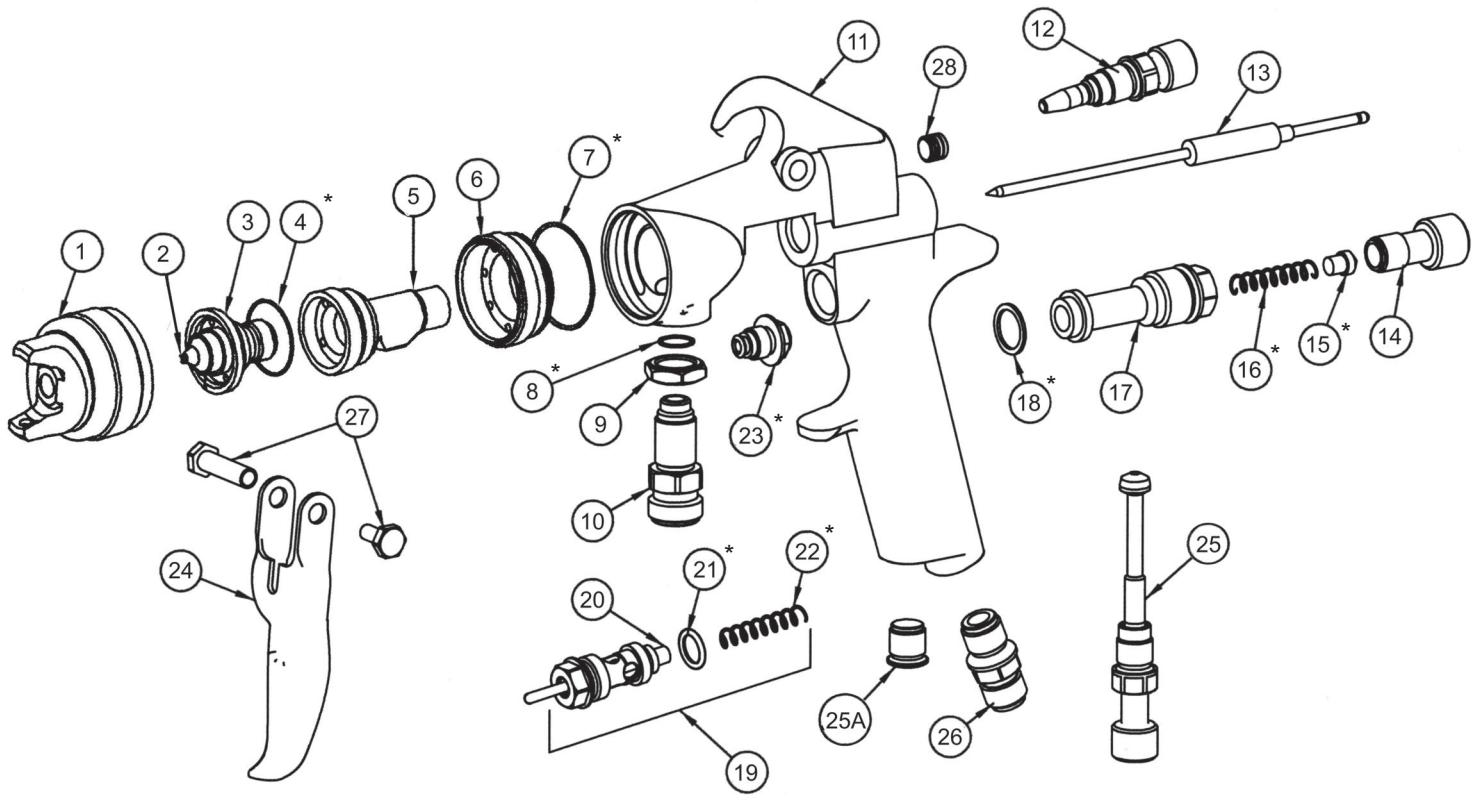

ITEM NO.	PART NO.	DESCRIPTION	ITEM NO.	PART NO.	DESCRIPTION
1	See Air Cap Chart	Air Cap**	16	60-204	Needle Return Spring*
2	See Air Cap Chart	Fluid Nozzle Tip**	17	60-201	Rear Bushing
3	32-2201	Fluid Nozzle Body	18	60-119	Seal*
4	98-8020	Gasket*	19	60-1520	Air Valve Assembly
5	60-L21C	Nozzle Carrier	20	60-302	Air Valve Poppet
6	60-22	Air Cap Adapter	21	60-125	O-Ring*
7	60-131	O-Ring*	22	61-1003	Air Valve Spring*
8	60-124	Fluid Inlet Seal	23	60-1400	Needle Seal Cartridge*
9	60-128	Locknut	24	60-2101	Trigger
10	60-126	Fluid Inlet Fitting	25	60-1510	Air Control
11	60-1124	Lynx Gun Body Conventional	25A	60-122	Plug (optional)
12	See Air Cap Chart	Fan Control Assembly**	26	60-104	Air Inlet Fitting
13	See Air Cap Chart	Fluid Needle**	27	60-1033	Trigger Pivot Set
14	60-202	Fluid Control Knob	28	98-0109	Allen Plug
15	60-205	Spring Seat*			

**See air cap selection chart on page 1

*Indicates part included in repair kit # 10-106

FLUID NOZZLE / AIR CAP SELECTION CHARTS

LYNX Series 200C - Pressure / Siphon Feed Guns

L200C CONVENTIONAL SPRAY GUN

MATERIAL TYPE	FLUID ORIFICE x AIR CAP	MAXIMUM PATTERN WIDTH	PRESS. / SIPHON
Very Thin less than 16 sec. Zahn #2 inks , dyes, solvents, stains	1.1 mm x 2058	9	P/S
	1.1 mm x 2030	10	S
Thin 16 to 20 sec. Zahn #2 lacquers, enamels, primers, sealers	1.1, 1.4 mm x 2058	9	P/S
	1.1, 1.4 mm x 2030	10	S
	1.1, 1.4 mm x 2900	10	S
Medium 21 to 30 sec. Zahn #2 automotive base coat enamels, primers epoxies, urethanes automotive clear coat	1.4, 1.8 mm x 2080	13	S
	1.4, 1.8 mm x 2704	12	P
	1.4, 1.8 mm x 2765	15	P
	1.4, 1.8 mm x 2777	14	P
	1.4, 1.8 mm x 2797	17	P
	1.4, 1.8 mm x 2900	10	S
Heavy over 30 sec. Zahn #2 heavy body primers high solid enamels high solid automotive coatings adhesives	1.8mm x 2765	15	P
	1.8mm x 2797	17	P
	2.2 mm x 2880	13	S
	2.2 mm x 2064	14	P