

# CET

Coating Equipment Technology, Inc  
Quality Spray Equipment. World Class Service.

## C.A. Technologies

### CA Tech 10 Gallon Tank (w/ Mixer)

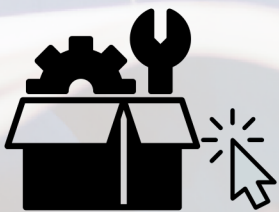

### CLICK-N-PICK SPARE PARTS CUTSHEET

Easily find spare parts without digging through the full manual.

[Click on part numbers to order.](#)



ENHANCED "INTERACTIVE" MANUAL

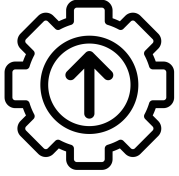

BLUE TEXT = CLICK TO ORDER 



**51-553** SINGLE REGULATED  
**51-554** DOUBLE REGULATED

**IMPORTANT NOTE:** IF THIS PRESSURE TANK IS TO BE USED FOR SPRAYING FLAMMABLE MATERIALS, OPERATOR MUST NOT PRESSURIZE THIS TANK MORE THAN 15 PSI TO MEET OSHA REQUIREMENTS. FOR NON-ASME PRESSURE VESSELS. IT IS THE RESPONSIBILITY OF THE OPERATOR TO FOLLOW THIS MANDATORY PROCEDURE.

## GENERAL INFORMATION

This pressure tank is equipped with either single or double air pressure regulation, material outlet shutoff valves for 2 guns, pressure safety relief valve, disposable plastic liner, an air powered agitator, and four caster wheels.

## CAUTION!

1. Maximum tank pressure of 80 psi. The safety relief valve is designed to protect the tank against excessive pressures. DO NOT attempt to make adjustments to this valve. If this valve begins to vent air, reduce the setting on the air inlet regulator.
2. DO NOT alter the tank in any way by welding, drilling or machining as this may weaken the structure of the tank.
3. To prevent hazardous static sparks from occurring, always ground the tank by connecting a 12 ga. wire to the tank and to a known earth ground.
4. Halogenated solvents will react chemically with aluminum and may cause an explosion. Examples of halogenated solvents are 111 trichlorethane and methylene chloride. **DO NOT use the removable aluminum tank liner with any halogenated solvents.**
5. Be sure tank pressure is completely relieved before attempting to remove tank cover or material fill cap. Shut off the main air supply to the tank and vent pressure using the vent valve located on the tank lid.

**\*\*NOTE\*\* Oilless Motor Used on CAT Agitated Tanks - DO NOT OIL TANK MOTORS**

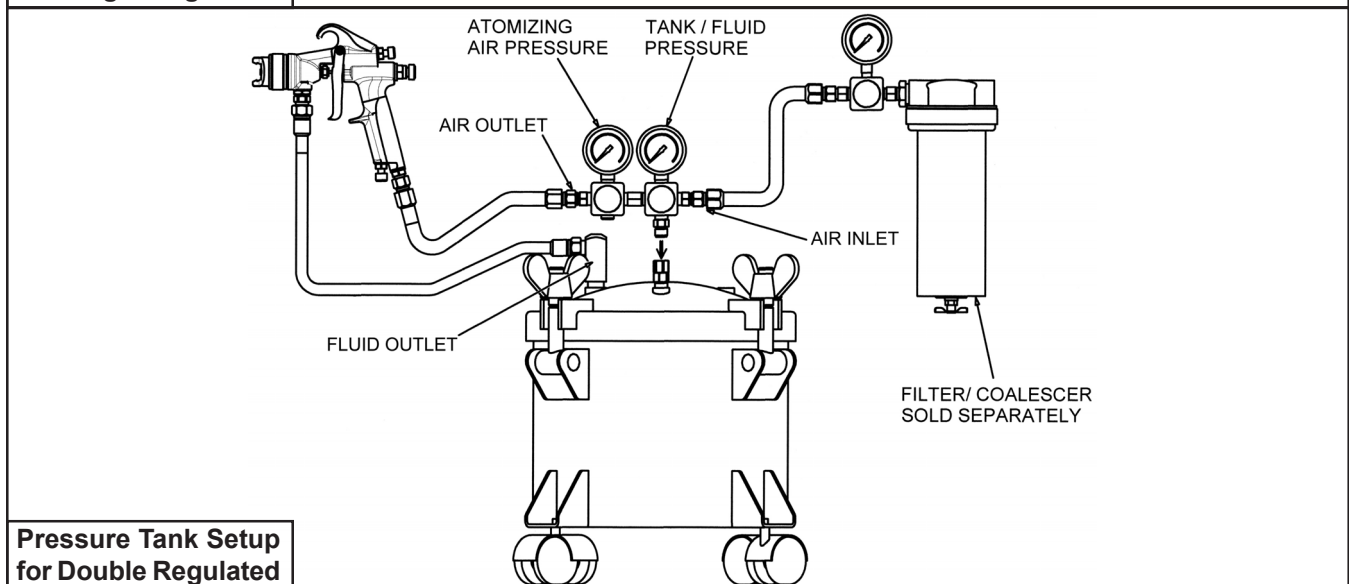
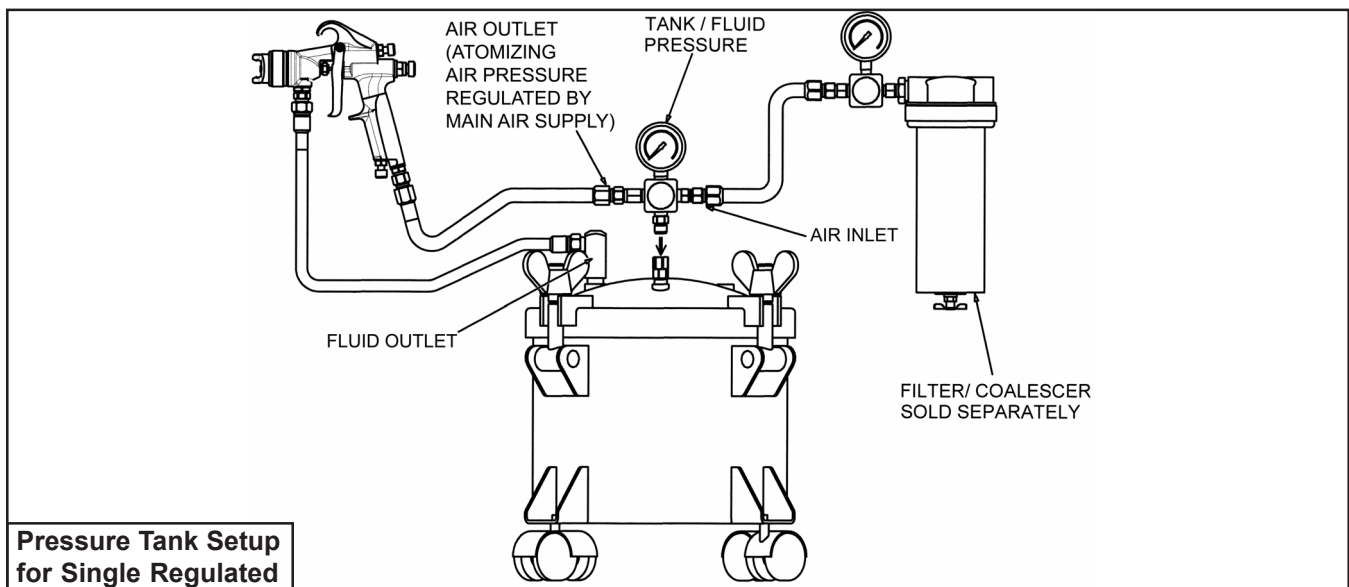

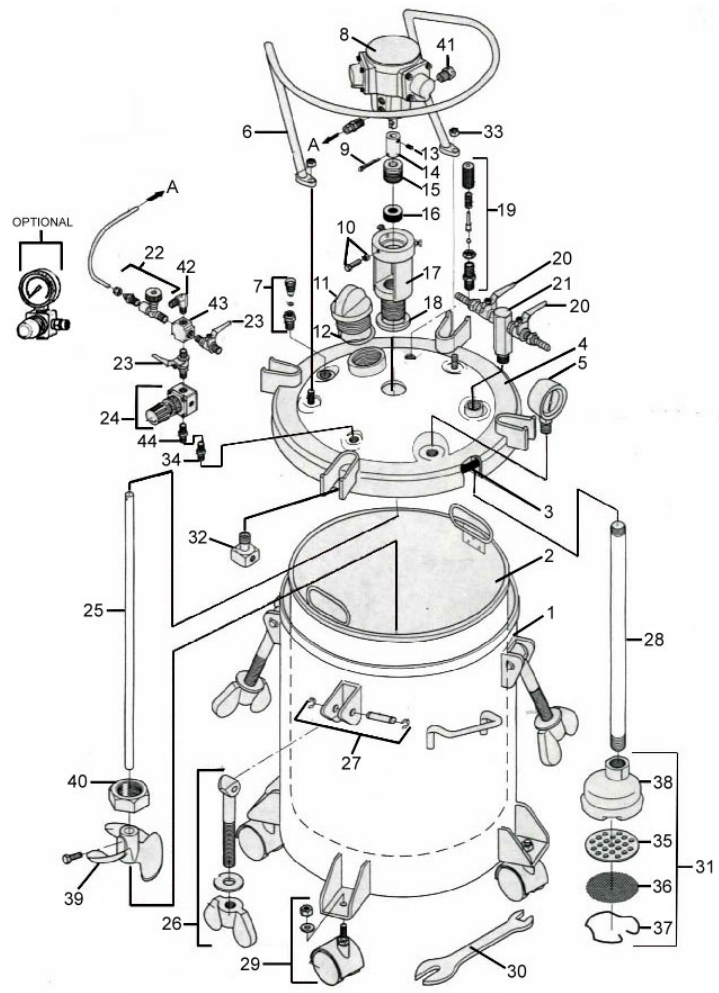

ITEM NO.	PART NO.	DESCRIPTION	ITEM NO.	PART NO.	DESCRIPTION
1	51-538	Tank Shell	23	52-150	Air Shut Off Valves
2	51-543-10	Disposable Plastic Tank Liner (10pk)	24	52-6	Air Regulator (51-222 Opt. 2nd Reg)
	51-539	Optional SS Tank Liner	25	51-545	Agitator Shaft
3	51-520	Gasket (Available in 3 Pack)	26	51-236	Eye Bolt Assembly
4	51-528	Tank Lid Assembly	27	51-233	Pin Assembly
5	52-58	Pressure Gage	28	51-534	Fluid Pickup Tube
6	51-535	Guard	29	51-224	Caster (51-252 Opt. Stationary Feet)
7	51-234	Tank Vent Valve	30	51-225	Wrench
8	51-240	Air Motor	31	51-532	Inlet Strainer Assembly
9	51-266	Roll Pin	32	51-237	Air Flow Diffuser
10	51-264	Screw & Nut 1/4-20 x 1' lg	33	98-0115	Nut 3/8-16
11	51-524	Material Fill Cap	34	52-1	Swivel Fitting
12	51-522	Seal Ring, Filler Cap	35	51-549	Inlet Screen Backup Plate
13	51-262	Set Screw 1/4-20 x 1/4 lg	36	51-542	Inlet Screen
14	51-242	Coupling	37	51-519	Inlet Screen Retaining Clip
15	51-288	Guide	38	51-548	Inlet Strainer Body
16	51-289	Chevron Packing Set	39	51-246	Propeller W/Bolt
17	51-287	Air Motor Base	40	51-259	Retaining Nut
18	51-245	Seal Ring	41	51-271	Muffler
19	51-229	Safety Relief Valve Assembly	42	51-268	90 Degree Elbow
20	52-151	Material Outlet Valve	43	51-267	4-Way Union
21	51-530	Material Outlet Manifold	44	53-562	1/4 x 1/4 Nipple Fitting
22	51-247	Speed Control Valve For Agitator			

**Pressure Tanks Available From C.A. Technologies**



2.5 Gallon Pressure Tank  
51-201 Single Regulated  
51-202 Double Regulated



2.5 Gallon Pressure Tank  
With Air Powered Agitation  
51-203 Single Regulated  
51-204 Double Regulated



5 Gallon Pressure Tank  
With No Agitation  
51-507 Single Regulated  
51-508 Double Regulated



5 Gallon Pressure Tank  
With Manual Agitation  
51-501 Single Regulated  
51-502 Double Regulated



5 Gallon Pressure Tank  
With Air Powered Agitation  
51-503 Single Regulated  
51-504 Double Regulated



10 Gallon Pressure Tank  
With No Agitation  
51-551 Single Regulated  
51-552 Double Regulated



10 Gallon Pressure Tank  
With Manual Agitation  
51-557 Single Regulated  
51-558 Double Regulated



10 Gallon Pressure Tank  
With Air Powered Agitation  
51-553 Single Regulated  
51-554 Double Regulated