

CET

Coating Equipment Technology, Inc
Quality Spray Equipment. World Class Service.

C.A. Technologies

CA Tech AutoCat A300C Spray Gun

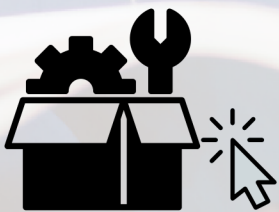

CLICK-N-PICK SPARE PARTS CUTSHEET

Easily find spare parts without digging through the full manual.

[Click on part numbers to order.](#)

BINKS

WALTHER
PILOT

WAGNER

GFS GLOBAL FINISHING SOLUTIONS

C.A. Technologies

DEVILBISS

SCHULZ

ENHANCED *INTERACTIVE* MANUAL

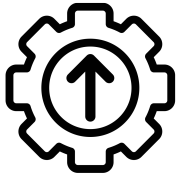

BLUE TEXT = CLICK TO ORDER



CONVENTIONAL AIR CAP AND FLUID NOZZLE CHART

MODEL NO.	AIR CAPS	Press / Siphon	*SUGGESTED GUN INLET PRESS.	FAN CONTROL ORIFICE	SCFM	AIR CAP RING	AVAILABLE FLUID NOZZLES	NEEDLES / marking on needle
A300C	23-2010*	p/s	45-55	None	9-10.7	23-0201	33-0608 0.8mm (.022")	40-A308 (308)
	23-2013*	p/s	45-55		9-10.7		33-0610 1.0mm (.040")	40-A310 (310)
	23-2014*	p/s	45-55		9-10.7		33-0613 1.3mm (.052")	40-A313 (313)
	23-2016*	p/s	45-55		9-10.7		33-0614 1.4mm (.055")	40-A314 (314)
							33-0616 1.6mm (.063")	40-A315 (315)

Actual fluid nozzle and air cap combinations are determined by application (see application chart page 4)

*Gun inlet pressures may vary as required by application



DISTRIBUTED BY COATING EQUIPMENT TECHNOLOGY, INC

PHONE: 586-210-0555

WEB: www.cetinc.com

Operation and Maintenance Instructions for *A300C* Spray Guns

Gun Mounting

A 1/2" dia. x 5" lg. rod is provided for mounting. The gun can be mounted from the left or right side or from the bottom. Thread the mounting rod (9) into one of the three holes that best suit the mounting location for the application. Tighten the locknut (10) to secure the gun in the position desired. Do not plug the remaining holes as they are used as drain holes in the event of a needle seal leak.

Operation: Connections and Adjustments

The automatic gun requires two separate regulated air supply lines.

1. Connect one air line to the fitting marked "CYL", this actuates the gun on and off and is usually connected through an air solenoid.
2. Connect the second air line to the fitting marked "ATM", this provides atomizing and fan air.
3. Connect a pressurized fluid supply to the gun fluid inlet.
4. Fluid flow can be controlled using the fluid control knob, this restricts flow by limiting needle travel. It is best to control fluid flow by proper selection of fluid orifice size and use the fluid control knob to "fine tune flow rate".
5. Fan width can be adjusted using the fan control knob. Turning the knob clockwise narrows the fan.

Maintenance: Needle Seal Replacement

IMPORTANT! Routine cleaning and maintenance is essential to insure proper gun operation.

Before beginning needle seal replacement, it is recommended kit no. 10-107 be on hand.

Several states prohibit spraying solvent into the atmosphere and require the use of covered gun cleaner.

1. Remove fluid control knob (36), needle return spring (34), and needle assembly (33).
2. Remove end cap (32) and piston return spring (31).
3. Piston (29) can be removed with pliers by carefully gripping the hub on the rear of the piston.
4. Remove the air control spool (22) using an 11/16" socket to unscrew it from the body.
5. The needle seal can be removed using a 7/16" socket with a short extension. Install a new needle seal and torque to approx. 2 ft.-lbs.
6. It is recommended that the o-rings on the air control spool (22) and piston (29) be replaced and lubricated before reassembling the gun.

NOTE: Gun head disassembly is not recommended for normal cleaning and maintenance.

Gun head disassembly and reassembly instructions:

Have repair kit # 10-107 available before gun disassembly.

Gun head disassembly

To remove the nozzle carrier (6) and air cap adapter (7):

1. Remove the air cap (1 & 2), fluid nozzle tip (3), fluid nozzle body (4), and needle (33).
2. Remove the needle seal cartridge (18) as described above.
3. Loosen the locknut (26) using 11/16" wrench and remove fluid inlet (27) using a 5/8" open-end wrench.
4. The nozzle carrier (6) and air cap adapter (7) will now slide forward from the gun body (11).

Gun head reassembly

1. Install a new o-ring (8) on the air cap adapter (7).
2. Install o-ring (5) between fluid nozzle body (4) and nozzle body carrier (6).
3. Install the thread locknut (26) onto the fluid inlet (27) as far as possible.
4. Install a new fluid inlet seal (25) into the recess area on the nozzle carrier (6) inlet port.
5. Slide the nozzle carrier (6) into air cap adapter (7) and insert into the gun body (11) as far as possible. Be sure the nozzle carrier (6) extends into the hole at the back of the gun head. Install the needle seal (18) but do not tighten.
6. Rotate the nozzle carrier (6) until the fluid inlet port in the nozzle carrier (6) is aligned with the threaded hole in the body. While in this position, insert the fluid inlet (27) and tighten firmly.
7. Tighten the needle seal (18) to approx. 12 ft.-lb. torque.
8. Tighten the fluid inlet (27) to approx. 25 ft.-lb. torque.
9. Tighten the locknut (26) to approx. 33 ft.-lb. torque.

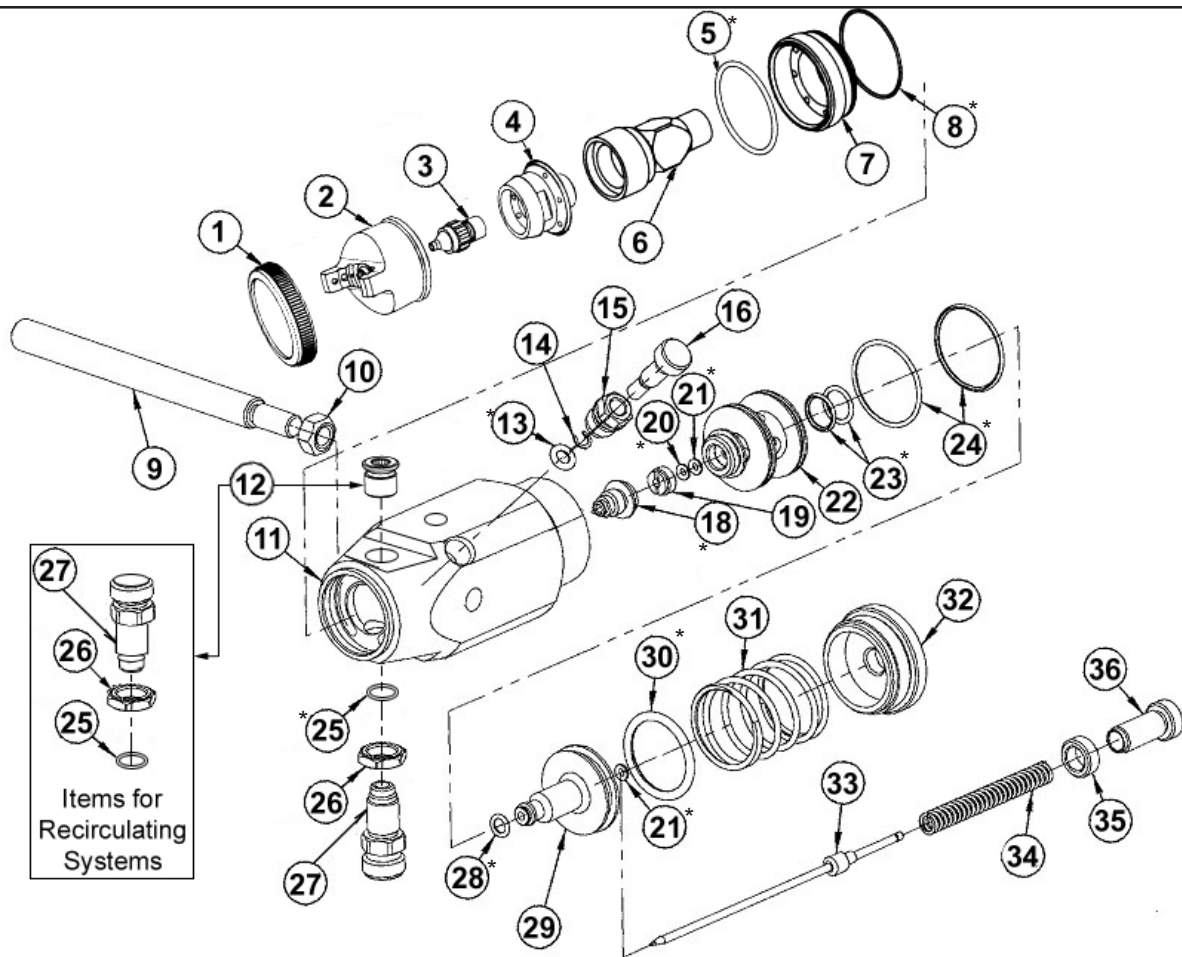

ITEM NO.	PART NO.	DESCRIPTION	ITEM NO.	PART NO.	DESCRIPTION
1	See Air Cap Chart	Air Cap Ring**	20	98-8006	O-Ring (Teflon)*
2	See Air Cap Chart	Air Cap**	21	98-7006	O-Ring (Viton) 2 Required*
3	See Air Cap Chart	Fluid Tip**	22	60-603	Air Control Spool
4	33-2201	Fluid Nozzle Body	23	98-7014	O-Ring (Viton) 2 Required*
5	98-8024	O-Ring (Teflon)*	24	98-7027	O-Ring (Viton) 2 Required*
6	60-L31C	Nozzle Body Carrier (Standard)	25	60-124	Seal*
	60-A31C-R	Nozzle Body Carrier (Recirculating)	26	60-128	Locknut
7	60-32C	Air Cap Adapter	27	60-126	Fluid Inlet
8	60-131	O-Ring (Teflon)*	28	98-8010	O-Ring (Teflon)*
9	60-614	Mounting Rod	29	60-602	Piston
10	98-0115	Locknut (3/8-16)	30	98-7217	O-Ring (Viton)*
11	60-622	AutoCAT Gun Body Conventional	31	66-246	Piston Return Spring
12	60-136	Plug	32	60-601	End Cap
13	98-8108	O-Ring (Teflon)*	33	See Air Cap Chart	Needle Assembly
14	98-0108	Circlip	34	60-613	Needle Return Spring
15	60-605	Fan Control Housing	35	60-612	Locknut - Fluid Control Knob
16	60-606	Fan Control Stem	36	60-608	Fluid Control Knob
18	60-1400	Needle Seal Assembly*	37	53-551 (Not Show n)***	Cylinder Air Fitting 1/8 NPT x 1/4 NPS
19	60-604	Seal Cap	38	53-552 (Not Show n)***	Atomz. Air Fitting 1/4 NPT x 1/4 NPT

*Indicates part included in repair kit # 10-107

**See air cap selection chart on page 1

***Air inlet fittings are available in 90 degree elbow . 90 degree elbow tubing "push on" style fittings

P/N 53-520 1/8 NPT x 1/4" OD Tube

P/N 53-521 1/4 NPT x 3/8" OD Tube

Recirculating setups require: Item 6 (recirculating) & items 25, 26, 27 in place of item 12

FLUID NOZZLE / AIR CAP SELECTION CHARTS

AUTOCAT Series 300C - Pressure / Siphon Feed Guns

A300C CONVENTIONAL AUTOMATIC SPRAY GUN

MATERIAL TYPE	FLUID ORIFICE x AIR CAP	MAXIMUM PATTERN WIDTH	PRESS. / SIPHON
Very Thin less than 16 sec. Zahn #2 inks , dyes, solvents, stains	0.8 mm x 2010	12	P/S
	1.0 mm x 2010	12	P/S
Thin 16 to 20 sec. Zahn #2 lacquers, enamels, primers, sealers	0.8 mm x 2010	12	P/S
	1.0 mm x 2010	12	P/S
	1.3 mm x 2013	12	P/S
Medium 21 to 30 sec. Zahn #2 automotive base coat enamels, primers epoxies, urethanes automotive clear coat	1.3 mm x 2013	12	P/S
	1.4 mm x 2014	12	P/S
	1.6 mm x 2016	12	P/S
Heavy over 30 sec. Zahn #2 heavy body primers high solid enamels high solid automotive coatings adhesives	1.4 mm x 2014	12	P/S
	1.6 mm x 2016	12	P/S