

CET

Coating Equipment Technology, Inc
Quality Spray Equipment. World Class Service.

C.A. Technologies

CA Tech CPR Spray Gun

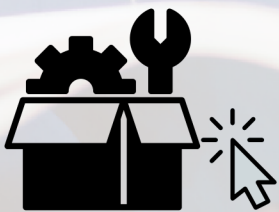

CLICK-N-PICK SPARE PARTS CUTSHEET

Easily find spare parts without digging through the full manual.

[Click on part numbers to order.](#)



ENHANCED *INTERACTIVE* MANUAL

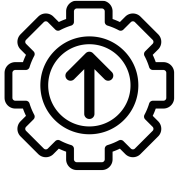

BLUE TEXT = CLICK TO ORDER



The CPR gun comes equipped with both a pressure reduced air cap 23-2101 and a HVLP air cap 23-1301 for areas requiring HVLP compliance.

23-2101 - consumes 11 cfm at 29 psi gun inlet.

23-1301 - consumes 13.5 cfm at 29 psi gun inlet.

23-2101 pressure reduced air caps can be used with the 0.8 mm - 1.7 mm fluid orifices listed below.

23-1301 HVLP air caps can be used with the full range of fluid orifices listed below.

HVLP/PRESSURE REDUCED AIR CAP AND FLUID NOZZLE CHART

MODEL NO.	AIR CAPS	FLUID TIP RANGE	*MAX GUN INLET PRESS. FOR HVLP	FAN CONTROL	SCFM @ MAX GUN INLET	STANDARD IN CAT PACK	AVAILABLE FLUID NOZZLES TIPS	NEEDLES / marking on needle	
CPR	23-2101 CPR (Pressure Reduced)	0.8 - 1.7	29*	60-1504 (S)	11	Included	33-0208 0.8mm (.022")	40-1308 (308)	
							33-0210 1.0mm (.040")	40-1310 (310)	
							33-0212 1.2mm (.046")	40-1312 (312)	
						Included	33-0213 1.3mm (.052")	40-1313 (313)	
							33-0214 1.4mm (.055")	40-1314 (314)	
	23-1301 (HVLP)	0.8 - 2.2	29*			13.5		33-0215 1.5mm (.059")	40-1315 (315)
							Included	33-0217 1.7mm (.070")	40-1317 (317)
								33-0219 1.9mm (.075")	40-1319 (319)
								33-0222 2.2mm (.086")	40-1322 (322)

Actual fluid nozzle and air cap combinations are determined by application (see application chart page 4)

*Note: Air cap test gages are available to confirm HVLP compliance.

*Gun inlet pressures may vary as required by application



DISTRIBUTED BY COATING EQUIPMENT TECHNOLOGY, INC

PHONE: 586-210-0555

WEB: www.cetinc.com

Operation and Maintenance Instructions for *CPR* Spray Guns

Operation

1. Connect air supply hose at handle of gun.
2. Connect a pressurized fluid supply to the gun fluid inlet.
3. Fluid flow can be controlled using the fluid control knob, this restricts flow by limiting needle travel. It is best to control fluid flow by proper selection of fluid orifice size and use the fluid control knob to “fine tune flow rate”.
4. Fan width can be adjusted using the fan control knob. Turning the knob clockwise narrows the fan.

Maintenance

IMPORTANT! Routine cleaning and maintenance is essential to insure proper gun operation.

Several states prohibit spraying solvent into the atmosphere and require the use of covered gun cleaner.

1. If a gun cleaner is being used, connect and clean the gun in the gun cleaner according to the manufactures instructions.
2. If a gun cleaner is not being used:
Remove air cap and clean separately using clean solvent.
For pressure setups, connect a pressurized solvent supply to the fluid inlet, trigger the gun allowing solvent to flow thru the gun until clean.

NOTE: Gun head disassembly is not recommended for normal cleaning and maintenance.

Gun head disassembly and reassembly instructions:

Have repair kit # 10-106 available before gun disassembly.

Gun head disassembly

To remove the nozzle carrier (4) and air cap adapter (6):

1. Remove the air cap (1), fluid nozzle tip (2), fluid nozzle body (3), and needle (13).
2. Remove the needle seal cartridge (23).
3. Loosen the locknut (9) and remove fluid inlet (10) using a 5/8” open-end wrench.
4. The nozzle carrier (4) and air cap adapter (6) will now slide forward from the gun body (11).

Gun head reassembly

1. Install a new o-ring (5 and 7) on the air cap adapter (6).
2. Install the thread locknut (9) onto the fluid inlet (10) as far as possible.
3. Install a new fluid inlet seal (8) into the recess area on the nozzle carrier (4) inlet port.
4. Slide the nozzle carrier (4) into air cap adapter (6) and insert into the gun body (11) as far as possible. Be sure the nozzle carrier (4) extends into the hole at the back of the gun head. Install the needle seal (23) but do not tighten.
5. Rotate the nozzle carrier (4) until the fluid inlet port in the nozzle carrier (4) is aligned with the threaded hole in the body. While in this position, insert the fluid inlet (10) and tighten firmly.
6. Tighten the needle seal (23) to approx. 12 ft.-lb. torque.
7. Tighten the fluid inlet (10) to approx. 25 ft.-lb. torque.
8. Tighten the locknut (9) to approx. 33 ft.-lb. torque.

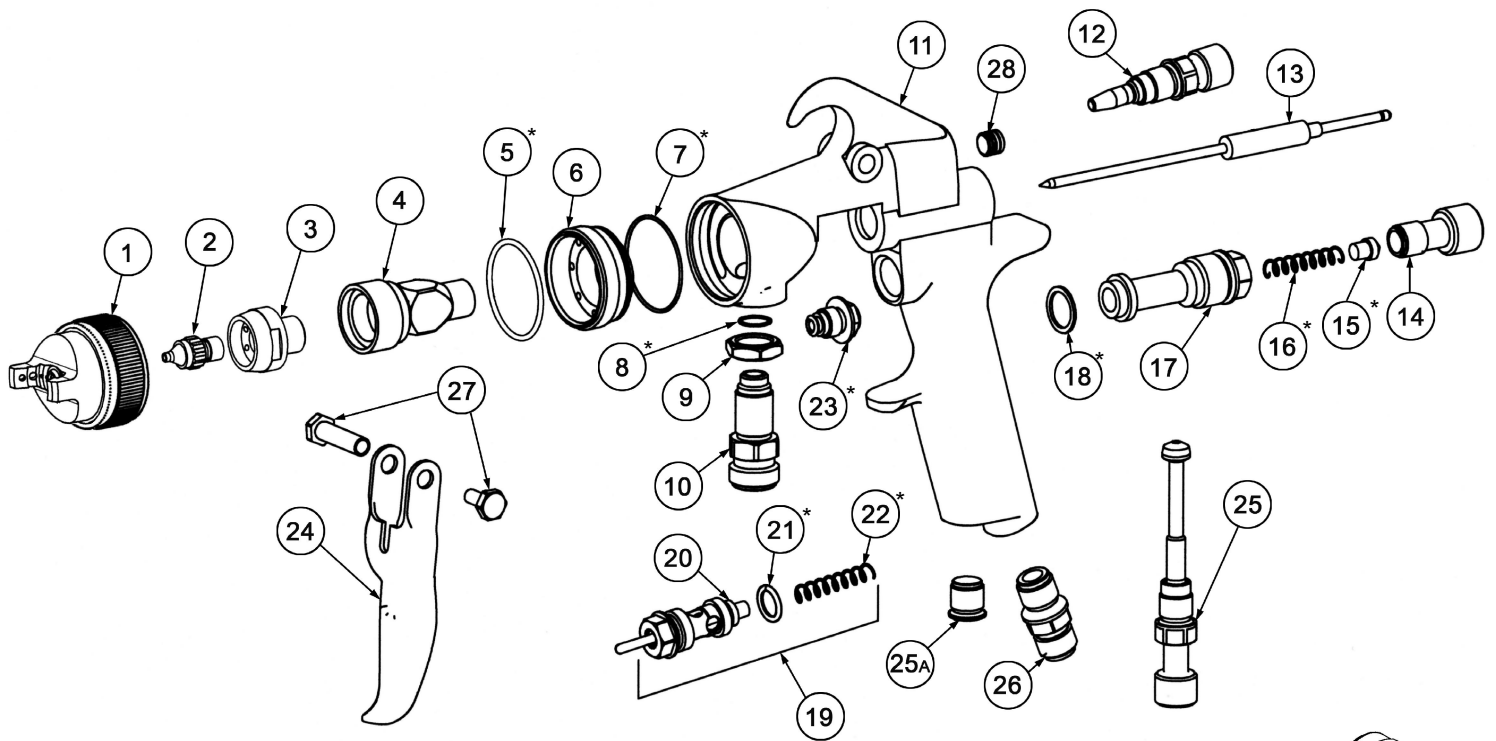

HVLP AIR CAP TEST GAGES

FOR CPR GUNS	23-1301-G
--------------	-----------

ITEM NO.	PART NO.	DESCRIPTION	ITEM NO.	PART NO.	DESCRIPTION
1	See Air Cap Chart	Air Cap**	16	60-204	Needle Return Spring*
2	See Air Cap Chart	Fluid Nozzle Tip**	17	60-201	Rear Bushing
3	33-1202	Fluid Nozzle Body	18	60-119	Seal*
4	60-L31H	Nozzle Carrier	19	60-1520	Air Valve Assembly
5	98-8026	O-Ring*	20	60-302	Air Valve Poppet
6	60-34H	Air Cap Adapter	21	60-125	O-Ring*
7	60-131	O-Ring*	22	61-1003	Air Valve Spring*
8	60-124	Fluid Inlet Seal*	23	60-1400	Needle Seal Cartridge*
9	60-128	Locknut	24	60-2101	Trigger
10	60-126	Fluid Inlet Fitting	25	60-1510	Air Control
11	60-1120-CPR	CPR Gun Body HVLP	25A	60-122	Plug (optional)
12	See Air Cap Chart	Fan Control Assembly**	26	60-104	Air Inlet Fitting
13	See Air Cap Chart	Fluid Needle**	27	60-1033	Trigger Pivot Set
14	60-202	Fluid Control Knob	28	98-0109	Allen Plug
15	60-205	Spring Seat*			

**See air cap selection chart on page 1

*Indicates part included in repair kit # 10-106

FLUID NOZZLE / AIR CAP SELECTION CHARTS

CPR Series - Pressure Feed Guns

CPR HVLP/PRESSURE REDUCED SPRAY GUN

MATERIAL TYPE	FLUID ORIFICE x AIR CAP	MAXIMUM PATTERN WIDTH	CFM
Very Thin less than 16 sec. Zahn #2 inks , dyes, solvents, stains	0.8 mm x 2101 or 1301 1.0 mm x 2101 or 1301	23-2101 13" 23-1301 12"	23-2101 11 CFM 23-1301 13.5 CFM
Thin 16 to 20 sec. Zahn #2 lacquers, enamels, primers, sealers	1.2 mm x 2101 or 1301 1.3 mm x 2101 or 1301	23-2101 13" 23-1301 12"	23-2101 11 CFM 23-1301 13.5 CFM
Medium 21 to 30 sec. Zahn #2 automotive base coat enamels, primers epoxies, urethanes automotive clear coat	1.3 mm x 2101 or 1301 1.4 mm x 2101 or 1301 1.5 mm x 2101 or 1301 1.7 mm x 2101 or 1301	23-2101 13" 23-1301 12"	23-2101 11 CFM 23-1301 13.5 CFM
Heavy over 30 sec. Zahn #2 heavy body primers high solid enamels high solid automotive coatings adhesives	1.7 mm x 2101 or 1301 1.9 mm x 1301 2.2 mm x 1301	23-2101 13" 23-1301 12"	23-2101 11 CFM 23-1301 13.5 CFM



CPR Smart Pack Includes:

- 98-0104 3/8" Socket
 - 98-0112 Ratchet Wrench
 - 60-8001 Gun Wrench
 - 98-0113 Gun Cleaning Brush
- Air Caps and Needles Shown on Page 1



CPR

CPR-303R2 Includes:

- 51-303 1 QT Aluminum Pressure Cup
 - 52-5R2 Pressure Cup Regulator
 - 98-0104 3/8" Socket
 - 98-0112 Ratchet Wrench
 - 60-8001 Gun Wrench
 - 98-0113 Gun Cleaning Brush
- Air Caps and Needles Shown on Page 1



CPR-303R2

CPR-PPSR2 Includes:

- 91-460 950 mL 3M™ PPST™ Pressure Cup
 - 91-462 Lids and Liners (Available in 25 Pack)
 - 91-475 #18 PPS Adapter
 - 52-5R2 Pressure Cup Regulator
 - 98-0104 3/8" Socket
 - 98-0112 Ratchet Wrench
 - 60-8001 Gun Wrench
 - 98-0113 Gun Cleaning Brush
- Air Caps and Needles Shown on Page 1



CPR-PPSR2