

CET

Coating Equipment Technology, Inc
Quality Spray Equipment. World Class Service.

C.A. Technologies

CA Tech 2.5 Gallon Pressure Tanks Stainless - Bottom Outlet - Agitated

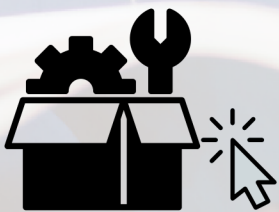

CLICK-N-PICK SPARE PARTS CUTSHEET

Easily find spare parts without digging through the full manual.

[Click on part numbers to order.](#)



2.5 GALLON SS (NON-ASME)
STAINLESS STEEL AIR AGITATED BOTTOM OUTLET
PRESSURE TANK PRODUCT INFORMATION

ENHANCED *INTERACTIVE* MANUAL

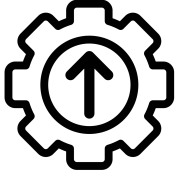

BLUE TEXT = CLICK TO ORDER 



- 51-915 NON REGULATED**
- 51-913 SINGLE REGULATED**
- 51-914 DOUBLE REGULATED**

IMPORTANT NOTE: IF THIS PRESSURE TANK IS TO BE USED FOR SPRAYING FLAMMABLE MATERIALS, OPERATOR MUST NOT PRESSURIZE THIS TANK MORE THAN 15 PSI TO MEET OSHA REQUIREMENTS. FOR NON-ASME PRESSURE VESSELS. IT IS THE RESPONSIBILITY OF THE OPERATOR TO FOLLOW THIS MANDATORY PROCEDURE.

GENERAL INFORMATION

This pressure tank is equipped with either single or double air pressure regulation, pressure safety relief valve, tank vent valve, bottom outlet ball valve, four caster wheels and air powered agitator.

1. Turn regulators to zero. Close ball valves. Turn agitator knob to off position. Fill tank with product and tighten down lid with wrench provided.
2. With air from compressor on, open ball valves. Adjust pot pressure as needed to flow material to gun.
3. Adjust gun regulator if provided, to atomize material as needed.
4. Adjust agitator knob to the slowest speed that mixes the material as needed.

CAUTION!

1. Maximum tank pressure of 80 psi. The safety relief valve is designed to protect the tank against excessive pressures. DO NOT attempt to make adjustments to this valve. If this valve begins to vent air, reduce the setting on the air inlet regulator.
2. DO NOT alter the tank in any way by welding, drilling or machining as this may weaken the structure of the tank.
3. To prevent hazardous static sparks from occurring, always ground the tank by connecting a 12 ga. wire to the tank and to a known earth ground.
4. Be sure tank pressure is completely relieved before attempting to remove tank cover or material fill cap. Shut off the main air supply to the tank and vent pressure using the vent valve located on the tank lid.

****NOTE** Oilless Motor Used on CAT Agitated Tanks - DO NOT OIL TANK MOTORS**

ITEM NO.	PART NO.	DESCRIPTION	ITEM NO.	PART NO.	DESCRIPTION
1	51-278SS	Tank Shell	18	51-238SS	Guard
2	51-220	Gasket (51-220-3 = 3 Pack)	19	98-0115	Nut 3/8-16
3	51-279SS	Tank Lid Assembly	20	51-240SS	Air Motor
4	51-229	Safety Relief Valve Assembly	21	51-271	Muffler
5	51-234	Tank Vent Valve	22	51-262	Set Screw 1/4-20 x 1" lg.
6	51-280	Swivel Connection	23	51-266	Roll Pin
7	52-10A	Fluid Regulator Assembly	24	51-242	Coupling
8	52-11A	Atomizing Air Regulator Assembly	25	51-288	Guide
9	52-58	Pressure Gauge	26	51-289	Shaft Seal Assembly
10	52-303	Dual Regulator Assembly	27	51-264	Screw & Nut 1/4-20 x 1/4 lg.
11	51-237	Air Flow Diffuser	28	51-287SS	Air Motor Base
12	51-236	Eye Bolt Assembly	29	51-245	Seal Ring
13	51-224	Caster (4 Req'd)	30	51-272	3-Way Union
	51-252	Optional Stationary Feet (4 Req'd)	31	51-239	Double Male Nipple
14	51-233	Pin Assembly	32	51-247	Speed Valve Control Assembly
15	51-275SS	Fluid Outlet Elbow	33	51-276SS	Agitator Shaft
16	51-274SS	Fluid Outlet Ball Valve	34	51-259SS	Retaining Nut
17	51-225	Wrench	35	51-246	Propeller W/Bolt

Note: (1) 98-0383 & (1) 53-555 are needed to adapt a standard 3/8" fluid hose fitting to the bottom outlet ball valve.

Single regulated supplied with item 7, double regulated supplied with items 7 & 8

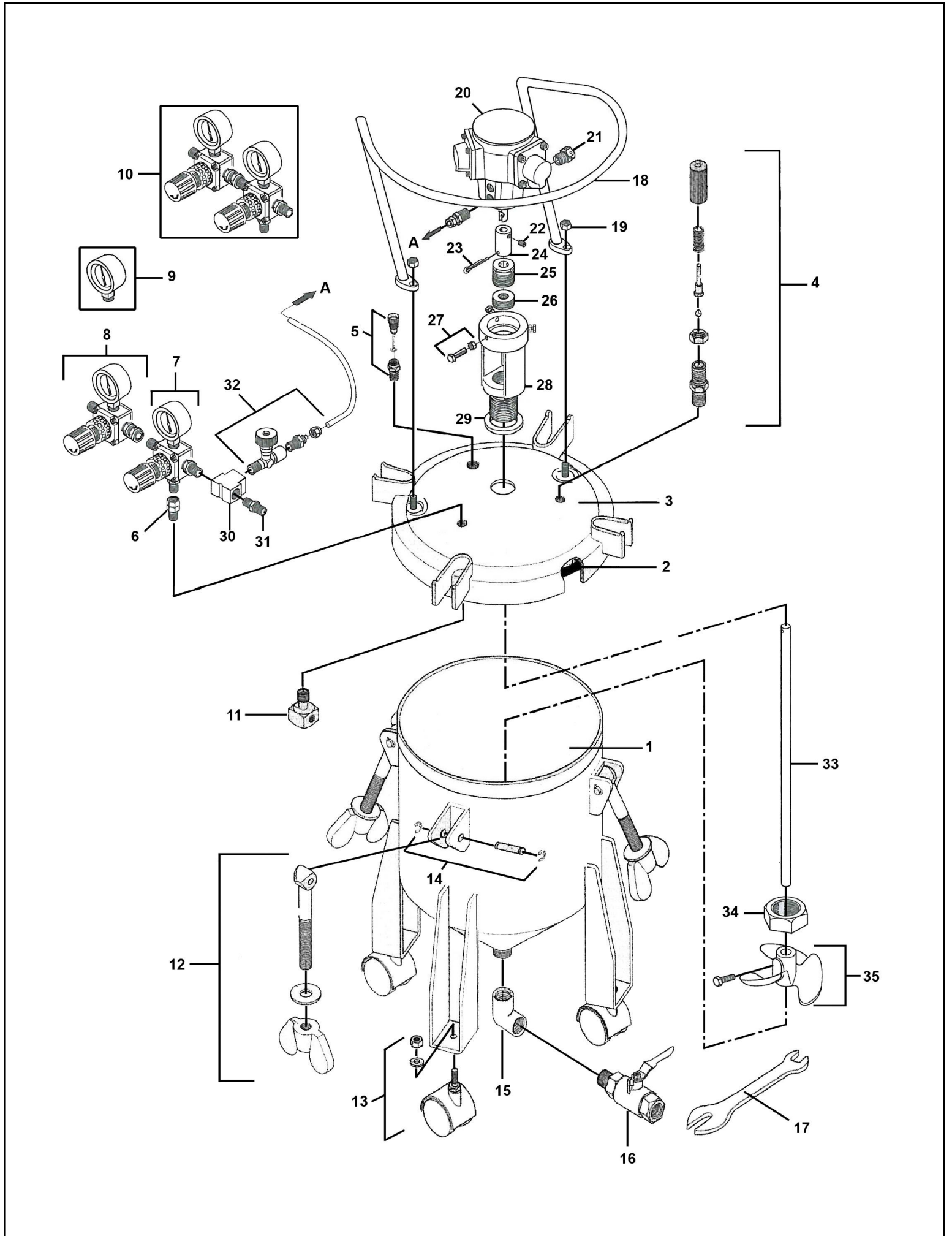

BOTTOM OUTLET SS PRESSURE TANKS

Bottom Outlet Pressure Tanks Available From C.A. Technologies



2.5 Gallon	PART NO.	REGULATORS	AGITATOR
	51-910	0	None
	51-911	1	None
	51-912	2	None
	51-913	1	Air
	51-914	2	Air
	51-915	0	Air

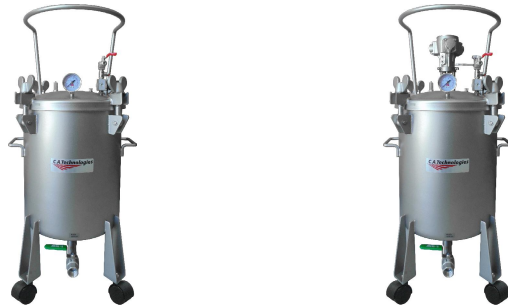

5 Gallon	PART NO.	REGULATORS	AGITATOR
	51-920	0	None
	51-921	1	None
	51-922	2	None
	51-923	1	Air
	51-924	2	Air
	51-925	0	Air



12.5 Gallon	PART NO.	REGULATORS	AGITATOR
	51-940	0	None
	51-941	1	None
	51-942	2	None
	51-943	1	Air
	51-944	2	Air
	51-945	0	Air