

CET

Coating Equipment Technology, Inc
Quality Spray Equipment. World Class Service.

C.A. Technologies

CA Tech CAT X Spray Gun

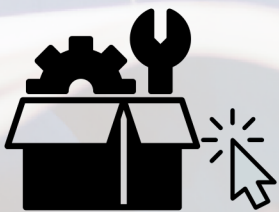

CLICK-N-PICK SPARE PARTS CUTSHEET

Easily find spare parts without digging through the full manual.

[Click on part numbers to order.](#)



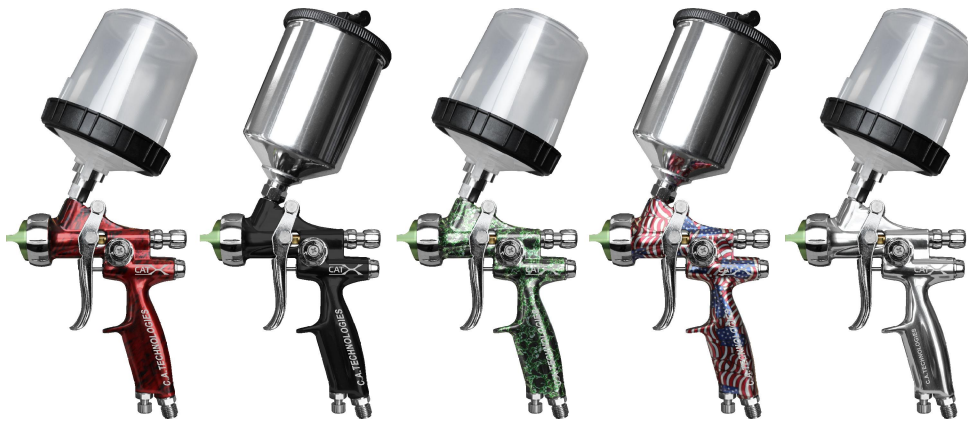
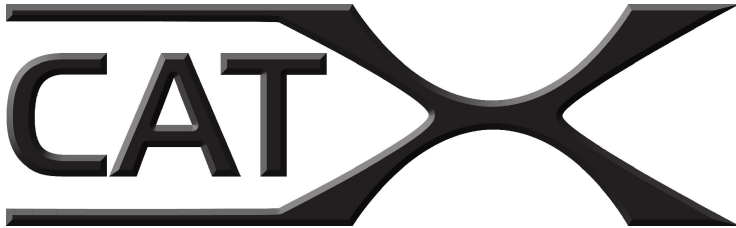
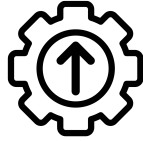

The CAT-X spray gun offers both a pressure reduced air cap 24-1352 and a HVLP air cap 24-1411 for areas requiring HVLP compliance.

24-1352 - consumes 11 cfm at 35 psi gun inlet.

24-1411 - consumes 13.5 cfm at 29 psi gun inlet - for areas requiring HVLP compliance.

24-1352 pressure reduced air caps can be used with the 1.0 mm - 1.7 mm fluid orifices listed below.

24-1411 HVLP air caps can be used with the full range of fluid orifices listed below.

HVLP/PRESSURE REDUCED AIR CAP AND FLUID NOZZLE CHART

MODEL NO.	AIR CAPS	FLUID TIP RANGE	*MAX GUN INLET PRESS. FOR HVLP	FAN CONTROL	SCFM @ MAX GUN INLET	AVAILABLE FLUID NOZZLE TIPS	NEEDLES / MARKING ON NEEDLE
CAT-X	24-1352 (Pressure Reduced)	0.8 - 1.7	35*	60-1385	11	33-0208 0.8mm (.022")	40-1408 (408)
						33-0210 1.0mm (.040")	40-1410 (410)
						33-0212 1.2mm (.046")	40-1412 (412)
						33-0213 1.3mm (.052")	40-1413 (413)
						33-0214 1.4mm (.055")	40-1414 (414)
	24-1411 (HVLP)	0.8 - 1.7	29*	60-1385	13.5	33-0215 1.5mm (.059")	40-1415 (415)
						33-0217 1.7mm (.070")	40-1417 (417)
						33-0219 1.9mm (.075")**	40-1419 (419)**
						33-0222 2.2mm (.086")**	40-1422 (422)**

Actual fluid nozzle and air cap combinations are determined by application (see application chart page 4)

*Note: Air cap test gages are available to confirm HVLP compliance.

*Gun inlet pressures may vary as required by application

**Needles and nozzles available for use with 24-1411 HVLP air cap only



DISTRIBUTED BY COATING EQUIPMENT TECHNOLOGY, INC

PHONE: 586-210-0555

WEB: www.cetinc.com

Operation and Maintenance Instructions for **CAT-X** Spray Guns

Operation

1. Connect air supply hose at handle of gun.
2. Screw the paint cup into the gun's fluid inlet port.
3. Fluid flow can be controlled using the fluid control knob, this restricts flow by limiting needle travel. It is best to control fluid flow by proper selection of fluid orifice size and use the fluid control knob to fine tune flow rate.
4. Fan width can be adjusted using the fan control knob. Turning the knob clockwise narrows the fan.

Maintenance

IMPORTANT! Routine cleaning and maintenance is essential to insure proper gun operation.

Several states prohibit spraying solvent into the atmosphere and require the use of covered gun cleaner.

1. If a gun cleaner is being used, connect and clean the gun in the gun cleaner according to the manufacturer's instructions.
2. If a gun cleaner is not being used, remove air cap and clean separately using clean solvent. Clean the gravity feed cup thoroughly, then spray clean solvent through the gun until clean. Remove and clean the needle with solvent, then reinstall. To prevent sluggish needle operation and premature seal failure, do not store the gun with the needle removed.

NOTE: Gun head disassembly is not recommended for normal cleaning and maintenance.

Gun head disassembly and reassembly instructions:

Have repair kit # 10-161 available before gun disassembly.

Gun head disassembly

To remove the nozzle carrier (10):

1. Remove the air cap (1), fluid nozzle tip (6), fluid nozzle body (7), baffle (8), and needle (17).
2. Remove the fluid inlet insert (15) with a 5/16 allen key (this will force o-ring (16) out of the fluid inlet bore) and extract the lower o-ring (9).
3. Withdraw the nozzle carrier (10) with needle seal items (11-13).

Gun head reassembly

1. Install a new needle seal (11), followed by packing spring (12) and packing nut (13) onto the air valve stem (26) as a temporary assembly guide. Insert the air valve stem with the needle seal parts into the nozzle carrier and tighten the packing nut while keeping the air valve pin inserted into the seal. Using the air valve pin as a temporary support prevents the needle seal from being overly compressed during installation which can cause the needle operation to be sluggish.
2. Install the o-ring (39) onto nozzle carrier (10).
3. Install the nozzle carrier (10) into the gun body.
4. Rotate the fluid inlet port to align with the gun body's fluid inlet.
5. Install carrier o-ring (9) into the recessed area of the nozzle carrier (10).
6. Making sure to keep the nozzle carrier pushed fully into the gun body, insert and tighten the fluid inlet insert (15) with a 5/16 allen key.
7. Install o-ring (16) as follows: fold the o-ring into an oval "potato chip" shape and press one side into the groove at the bottom of the threaded fluid inlet bore. Use a blunt punch to progressively work the o-ring into the groove. Finish forming the o-ring into the groove by threading in an aluminum cup or 3M PPS adapter
8. Align the baffle (8) to have its pin insert directly into the top center hole of the gun body. If done correctly, the baffle should not rotate.
9. Insert o-ring (9) into the nozzle carrier (10), followed by the nozzle body (7). Tighten the nozzle body with a 13/16 socket.
10. Remove the air valve pin from the needle seal, then install and tighten fluid nozzle (6) and air cap (1).

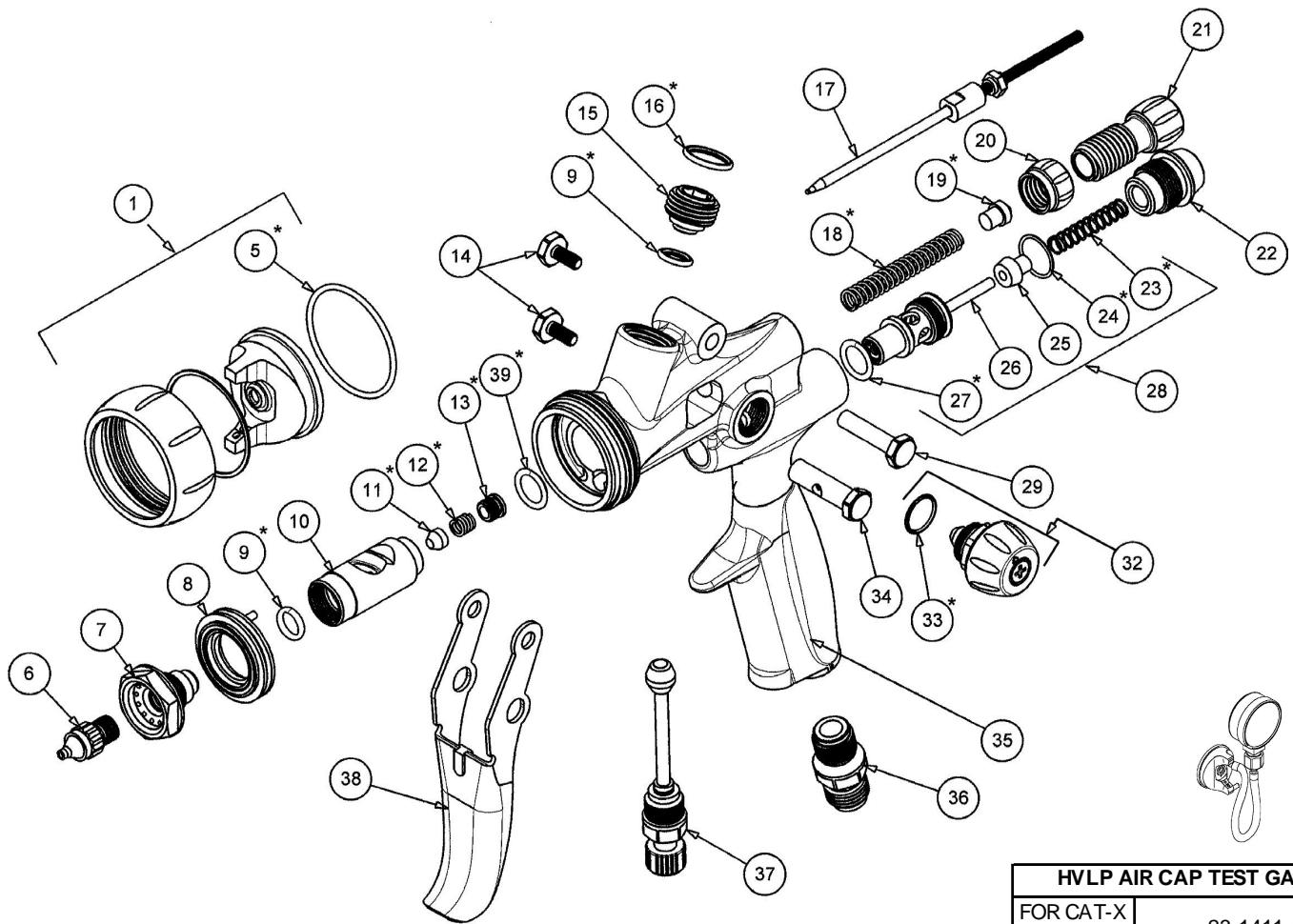

HVLP AIR CAP TEST GAGES	
FOR CAT-X GUNS	23-1411-G

ITEM NO.	PART NO.	DESCRIPTION	ITEM NO.	PART NO.	DESCRIPTION
1	See Air Cap Chart	Air Cap Assembly**	24	98-5125	O-Ring*
5	98-8028	O-Ring*	25	61-1032	Air Valve Poppet
6	See Air Cap Chart	Fluid Nozzle**	26	60-1371	Air Valve Stem
7	60-1360	Nozzle Body	27	98-8012	O-Ring*
8	60-1386	Baffle	28	60-1379	Air Valve Insert Assembly
9	98-8011	O-Ring*	29	60-1368	Trigger Pivot Pin
10	60-1362	Nozzle Body Carrier	32	60-1385	Fan Control Assembly
11	60-1365	Needle Seal*	33	98-5110	O-Ring*
12	60-1366	Packing Spring*	34	60-1369	Trigger Barrel
13	60-1364	Packing Nut*	35	60-1355-B	Handle Machining - Black Teflon™
14	60-1378	Trigger Screw		60-1355-C	Handle Machining - Classic
15	60-1363	Fluid Inlet Insert		60-1355-F	Handle Machining - Flag Pattern
16	98-8014	O-Ring*		60-1355-M	Handle Machining - Red Marble
17	See Air Cap Chart	Fluid Needle**		60-1355-S	Handle Machining - Skulls
18	60-204	Needle Return Spring*	36	60-104	Air Inlet Fitting
19	60-205	Spring Seat*	37	60-1319	Air Control Assembly
20	60-1377	Material Control Lock	38	60-1370	Trigger
21	60-1376	Material Control Knob	39	98-7013	O-Ring*
22	60-1375	Rear Cap	*	10-161	Repair Kit
23	61-1003	Air Valve Spring*			

**See air cap selection chart on page 1

*Indicates part included in repair kit # 10-161

FLUID NOZZLE / AIR CAP SELECTION CHARTS

CAT-X Series - Gravity Feed Guns

CAT-X HVLP/PRESSURE REDUCED SPRAY GUN

MATERIAL TYPE	FLUID ORIFICE x AIR CAP	MAXIMUM PATTERN WIDTH	CFM
Very Thin less than 16 sec. Zahn #2 inks , dyes, solvents, stains	0.8 mm x 1352 or 1411 1.0 mm x 1352 or 1411	24-1352 14" 24-1411 13"	24-1352 11 CFM 24-1411 13.5 CFM
Thin 16 to 20 sec. Zahn #2 lacquers, enamels, primers, sealers	1.2 mm x 1352 or 1411 1.3 mm x 1352 or 1411	24-1352 14" 24-1411 13"	24-1352 11 CFM 24-1411 13.5 CFM
Medium 21 to 30 sec. Zahn #2 automotive base coat enamels, primers epoxies, urethanes automotive clear coat	1.3 mm x 1352 or 1411 1.4 mm x 1352 or 1411 1.5 mm x 1352 or 1411 1.7 mm x 1352 or 1411	24-1352 13" 24-1411 12"	24-1352 11 CFM 24-1411 13.5 CFM
Heavy over 30 sec. Zahn #2 heavy body primers high solid enamels high solid automotive coatings adhesives	1.7 mm x 1352 or 1411 1.9 mm x 1411 2.2 mm x 1411	24-1352 13" 24-1411 12"	24-1352 11 CFM 24-1411 13.5 CFM



CAT-X



CAT-X-PPS

CAT-X Includes:

- 51-404 700 mL Aluminum Gravity Cup (Male Thread)
 - 52-300 Mini Regulator
 - 98-0104 3/8" Socket
 - 98-0112 Ratchet Wrench
 - 60-8001 Gun Wrench
 - 98-0113 Gun Cleaning Brush
 - 51-430 Gravity Gun Hook
- Air Caps and Needles Shown on Page 1

CAT-X-PPS Includes:

- 91-465 650 mL PPS™ Cup and Collar
 - 91-466 Lids and Liners (Available in 50 Pack)
 - 91-476 #27 PPS Adapter
 - 52-300 Mini Regulator
 - 98-0104 3/8" Socket
 - 98-0112 Ratchet Wrench
 - 60-8001 Gun Wrench
 - 98-0113 Gun Cleaning Brush
- Air Caps and Needles Shown on Page 1

CAT-X



EP-CAT-X Includes:

- 51-404 700 mL Aluminum Gravity Cup (Male Thread)
 - 98-0104 3/8" Socket
 - 98-0112 Ratchet Wrench
 - 60-8001 Gun Wrench
 - 98-0113 Gun Cleaning Brush
- Air Caps and Needles Shown on Page 1

EP-CAT-X-PPS Includes:

- 91-465 650 mL PPS™ Cup and Collar
 - 91-466 Lids and Liners (Available in 50 Pack)
 - 91-476 #27 PPS Adapter
 - 98-0104 3/8" Socket
 - 98-0112 Ratchet Wrench
 - 60-8001 Gun Wrench
 - 98-0113 Gun Cleaning Brush
- Air Caps and Needles Shown on Page 1